



Handling Systems

# Ergonomic Vacuum Lifters

[WWW.SCHMALZ.COM/VACUUM-LIFTERS](http://WWW.SCHMALZ.COM/VACUUM-LIFTERS)



**Schmalz is the market leader in ergonomic handling solutions and vacuum automation.**

**1,200**

EMPLOYEES  
WORLDWIDE



18 SUBSIDIARIES  
WORLDWIDE

**450**

INDUSTRIAL RIGHTS  
REGISTERED AND GRANTED

**8.5%**

OF TURNOVER FOR RESEARCH  
AND DEVELOPMENT

## OUR PORTFOLIO

The wide range of products in the Vacuum Automation unit includes individual components such as suction cups and vacuum generators, as well as complete gripping systems and clamping solutions for holding workpieces, for example in CNC machining centers. The Handling Systems unit offers innovative handling solutions with vacuum lifters and crane systems for industrial and handicraft applications. The intelligent solutions make production and logistics processes more flexible and efficient, while also preparing them for the increasing trend toward digitalization.

### Vacuum Automation



Components



Systems



Clamping and OEM Solutions

### Handling Systems



Vacuum Lifters and Crane  
Systems

# Vacuum Lifters and Crane Systems from Schmalz

## APPLICATIONS



LOGISTICS



WOOD



GLASS

**4** Practical Examples  
Vacuum Lifters in Selected  
Industries



METAL



AUTOMOTIVE



CHEMISTRY

## PRODUCTS



**12** Tube Lifters Jumbo  
Move Goods Weighing up  
to 300 kg Quickly and Easily

Selection aid: Jumbo or  
VacuMaster? — P. 46



**24** Lifting Devices  
VacuMaster  
Move Heavy Loads  
Weighing up to Several Tons  
Ergonomically and Securely  
Selection aid: Jumbo or  
VacuMaster? — P. 46



**40** Crane Systems  
Aluminum Crane Systems and  
Jib Cranes that are Designed  
Specifically for Your Handling  
System

## FROM TASK TO SOLUTION



**44** Select, Service,  
Contact  
We Help you Find a Solution  
That Allows to Work More  
Quickly, More Ergonomically,  
and More Efficiently



## SEE OUR VACUUM LIFTERS IN ACTION

The Schmalz Media Center will take you with few clicks  
to the application examples in your industry segment –  
user-friendly, informative and practical.

[WWW.SCHMALZ.COM/VIDEO](http://WWW.SCHMALZ.COM/VIDEO)

▶ Vacuum tube lifter JumboFlex for lifting cardboard boxes

▼ Vacuum tube lifter JumboFlex for handling packages in goods receiving/shipping



## *The Right Solution for any Task.*

Vacuum handling systems from Schmalz are used in a wide variety of industries to ensure efficient material flows. Our many years of experience and our close relationships with our customers mean we understand your processes, which allows us to produce products to meet the highest standards. They allow loads to be handled faster and more securely while protecting both the materials and your employees. At your request, Schmalz can provide you with a complete workplace solution consisting of a handling system and a crane designed to work perfectly with that system.



## LOGISTICS

### Flexible Handling Solutions for Intra-Logistics, Distribution Logistics and Baggage Logistics

Whether in the goods receiving or shipping area, in a parcel distribution center or in an airport – anywhere goods are moved quickly and frequently, the vacuum tube lifter Jumbo ensures efficient material flows while easing the burden on your employees.



Vacuum tube lifter JumboFlex for lifting packages and for loading sorting and distribution machines



Vacuum tube lifter JumboErgo for lifting cardboard boxes



Vacuum tube lifter JumboFlex for handling baggage at airports



Vacuum tube lifter JumboErgo for packaging goods into boxes and handling the sealed boxes

## Efficient Machine Loading for all Types of Wooden Boards

The woodworking industry has relied on Schmalz handling systems for decades. They are used in combination with CNC machining centers or panel saws to ensure efficient operation and can fulfill the most demanding requirements, such as turning or swiveling workpieces.



Vacuum tube lifter JumboErgo for loading and unloading a CNC machining center



Vacuum lifting device VacuMaster Comfort for turning coated wooden boards by 180°



Vacuum tube lifter JumboErgo with 90° swivel angle for loading a CNC machining center



Vacuum lifting device VacuMaster Multi with 90° swivel angle for handling heavy, porous wooden boards



GLASS

## The Highest Level of Security and Precision

Fragile windows and glass sheets require an especially gentle handling process. Vacuum handling allows a single person to easily move even heavy glass components without the risk of breakage.



Vacuum lifting device VacuMaster Window Comfort for vertical handling of a multi-sash window



Vacuum lifting device VacuMaster Window for vertical handling of glass elements



Vacuum lifting device VacuMaster Window Comfort for loading and unloading a glazing press



Vacuum lifting device VacuMaster Comfort for turning a glass sheet by 180°



## METAL AND SHEET METAL

### Increase Production Efficiency with Effective Machine Loading

Using Schmalz handling systems to load and unload punching machines, bending machines or CNC laser cutting systems reduces downtime while protecting the surface of sensitive workpieces. They can also be used to optimize handling of metal sections and coils.



Vacuum lifting device VacuMaster Basic for loading and unloading a laser cutting machine



Vacuum lifting device VacuMaster Comfort for loading and unloading a laser cutting machine



Vacuum lifting device VacuMaster Coil with 90° swivel angle for handling coils



Vacuum lifting device VacuMaster Eco for energy-independent handling metal parts





## AUTOMOTIVE

### Move Goods Quickly and Easily

In manufacturing workflows manual processes such as loading and unloading of presses, handling of boxes and small load carriers in in-house logistics and components are supplied to the line. Vacuum lifters relieve operators of the weight of the workpieces, allowing them to work ergonomically.



Vacuum tube lifter JumboErgo for handling car body parts



Vacuum lifting device VacuMaster for handling roofs in caravan construction



Vacuum tube lifter JumboFlex Battery for handling batteries



Vacuum tube lifter JumboFlex for handling transport and storage boxes



## CHEMICALS AND PHARMACEUTICALS

### Reliable Handling of Goods in Potential Hazard Zones

In the chemical and pharmaceutical industry, safety is of the utmost importance when handling loads. Schmalz products allow bags, barrels, buckets and jugs to be handled smoothly and efficiently. Special solutions are available for explosion protection areas (see page 23).



Vacuum tube lifter JumboSprint Ex for handling bags in an explosion protection zone



Vacuum tube lifter JumboErgo with mechanical gripper for handling jugs



Vacuum tube lifter JumboFlex for palletizing plastic bags



Vacuum tube lifter JumboErgo with an area gripper for handling four barrels at once



## The Right Handling Solution for any Task

Schmalz handling systems ensure efficient material flows in a number of other industries: From universally applicable standard devices to customer-specific solutions, Schmalz is your partner for vacuum handling.



**Beverage industry** | Vacuum tube lifter JumboErgo with mechanical pneumatic grippers for lifting and turning kegs



**Solar** | Vacuum tube lifter JumboErgo with 90° swivel angle for handling solar panels



**Wind energy** | Vacuum lifting device VacuMaster for GRP components in rotor blade manufacturing weighing several tons and up to 60 m in length



**Custom solutions** | Vacuum lifting device VacuMaster Box employed in the assembly of large advertising signs

▶ Vacuum tube lifter JumboErgo for packaging goods into boxes

▼ Vacuum tube lifter JumboSprint Ex for handling bags in an explosion protection zone

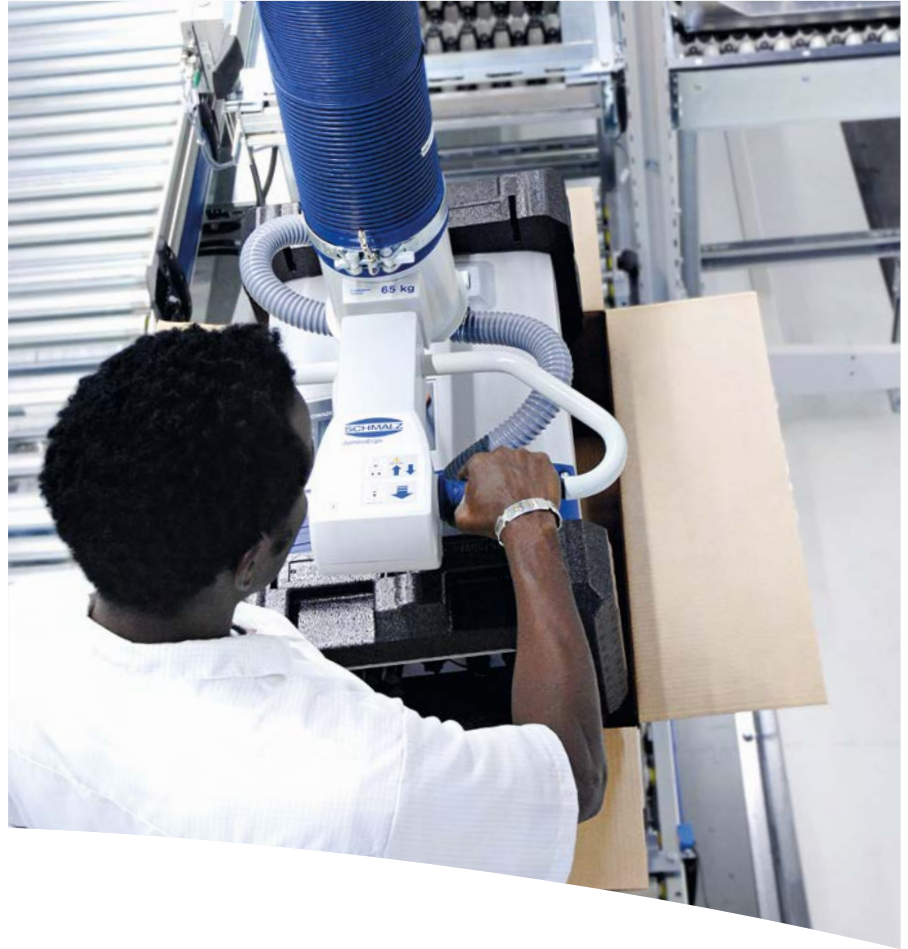

## *Tube Lifters Jumbo – Great Help for Small Loads.*

Cardboard boxes, bags, barrels, wooden boards and a variety of other applications – the vacuum tube lifter Jumbo tackles big jobs in the shortest amount of time. The intuitive operation allows you to move loads quickly, precisely and always ergonomically. It is the ideal aid for machine loading, for shipping and picking areas and for many other lifting applications.

# Vacuum Tube Lifters Jumbo

Move Goods Weighing up to 300 kg Quickly and Easily

## APPLICATION

Fast and frequent lifting and moving of workpieces weighing up to 300 kg, for example:

- Handling goods such as cardboard boxes, bags, barrels, buckets and jugs within in-house logistics processes
- Loading and unloading CNC machining centers

## YOUR BENEFITS

- Increased productivity thanks to reduced handling and loading times
- Secure, damage-free gripping by using vacuum
- Minimization of downtime due to employee injury
- Increase in employee motivation
- Only one person for handling

## DESIGN AND FUNCTION

The lifting unit, operating unit, vacuum grippers and vacuum generator on the vacuum tube lifter Jumbo can be configured according to customer specifications. The Jumbo is characterized by its lifting unit, which contracts and extends when lifting and lowering the load. The large effective suction area confers a safe holding of the workpiece. Schmalz also offers a comprehensive range of accessories and a complete system with a highly responsive aluminum crane upon request.

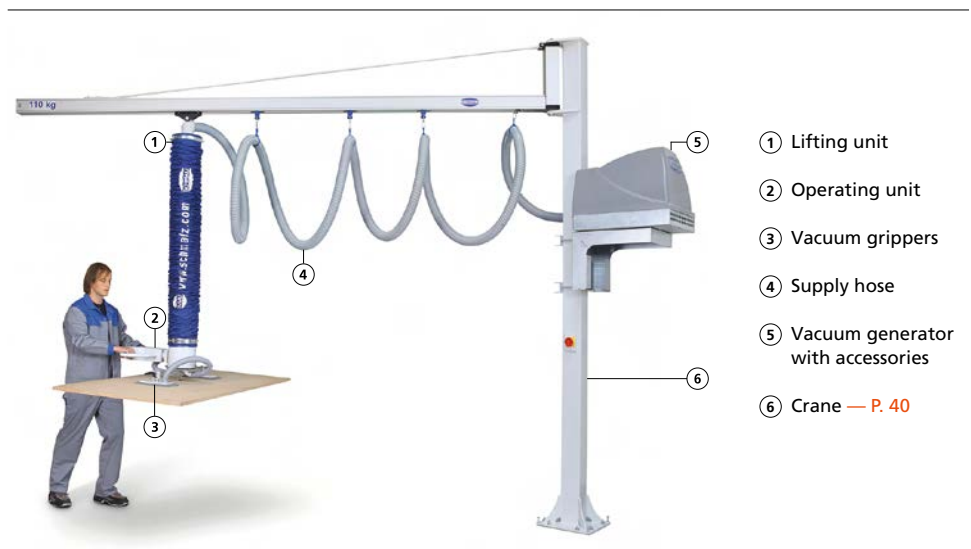

The entire system and its individual parts

## PRODUCT OVERVIEW

Three high-performance types for a variety of applications: JumboFlex, JumboErgo and JumboSprint differ in the form and function of their operator handles and are conceived in each case for specific applications.

Type	Max. lift capacity (horizontal)									
	20 kg	35 kg	45 kg	50 kg	65 kg	85 kg	110 kg	140 kg	200 kg	300 kg
JumboFlex	▶									
JumboErgo/JumboSprint	▶									



**JumboFlex**  
One-hand operation for workpieces weighing up to 50 kg  
— P. 14



**JumboErgo**  
For workpieces of different shapes and sizes weighing up to 300 kg — P. 18



**JumboSprint**  
For compact workpieces weighing up to 300 kg  
— P. 18

# JumboFlex

Lift Capacity up to 50 kg

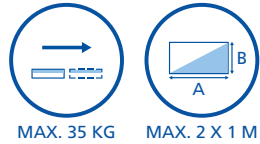

MAX. 35 KG    MAX. 2 X 1 M

- ① Lifting unit with protective tube
- ② Suspension height can be adjusted without a load attached
- ③ Filter, changeable without tools
- ④ One-finger control for lifting, lowering and releasing the load
- ⑤ Ergonomic control handle with non-slip elements
- ⑥ Continuous rotation, can be locked in 90° increments
- ⑦ Quick-change adapter for fast, tool-free gripper change
- ⑧ Vacuum grippers, adapted to the workpiece
- ⑨ 90° slewing mechanism (manual) for picking up loads from the side
- ⑩ Radio remote control SRC for vacuum generator (optional)

JumboFlex 35

The vacuum tube lifter JumboFlex allows you to move lighter goods up to 50 kg ergonomically and with high cycle rates. The control handle fits comfortably in the hand and allows the operator to work for a long period of time without fatigue. With the simple one-finger control, lifting, lowering and releasing the load is extremely

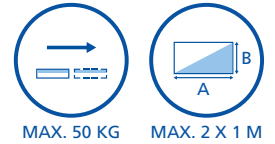

MAX. 50 KG    MAX. 2 X 1 M

- ① Lifting unit with protective tube
- ② Radio remote control SRC for vacuum generator (optional)
- ③ Suspension height can be adjusted without a load attached
- ④ Ergonomic control handle with non-slip elements
- ⑤ Continuous rotation, can be locked in 90° increments
- ⑥ Quick-change adapter for fast, tool-free gripper change
- ⑦ Vacuum grippers, adapted to the workpiece
- ⑧ 90° slewing mechanism (manual) for picking up loads from the side
- ⑨ One-finger or two-finger control for lifting, lowering and releasing the load

JumboFlex 50

intuitive. The JumboFlex's wide range of features allows it to tackle virtually any task. It comes standard with a quick-change system for replacing the vacuum grippers. Workpieces which are gripped from the vertical side automatically swing back into the horizontal position where they can be continuously rotated.

**Quick-change adapter  
as standard**



## VACUUM GRIPPERS

Versatility is key: Schmalz offers the correct vacuum grippers for virtually any application. With the quick-change adapter the gripper can be changed quickly and easily.



**Round vacuum gripper**  
For compact goods such as cardboard boxes, barrels, buckets, jugs and cabinets.



**Round vacuum gripper with skirt**  
For optimal sealing on plastic bags and shrink-wrapped packages.



**Double vacuum gripper**  
For stapled, glued, strapped or open cardboard boxes as well as small wooden boards.



**Quadruple vacuum gripper**  
For large cardboard boxes, wooden boards and other flat workpieces.



**Multiple vacuum gripper**  
For uneven workpieces such as foil trays or unstable cardboard boxes. The individual vacuum grippers compensate for any unevenness.



**2-in-1 gripper**  
Combination of a vacuum gripper and a suspension hook for baggage pieces such as suitcases or bags.



**Suspension hook**  
For mechanical suspension of buckets, jugs and other workpieces with a point from which to hang.



**Box gripper**  
For transport and storage boxes from all commercial manufacturers.

## VACUUM GENERATORS



**Pump EVE**  
Electric vacuum generator with short evacuation times and low power consumption.



**Ejector SEM**  
Compact compressed air vacuum generator with a high flow rate (up to JumboFlex 35).

# JumboFlex

## ACCESSORIES



**Save up to 40% in energy with the push of a button**  
 With the radio remote control SRC, you can directly switch off the vacuum generator on the operator handle when not in use and then back on again. The radio remote control is activated by a simple button push and needs no energy source due to an integrated induction generator.

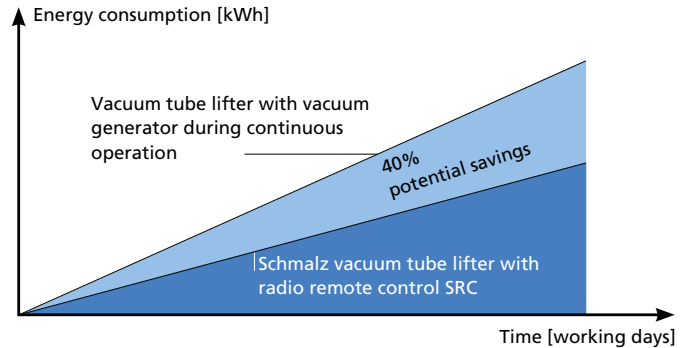

Potential energy savings with radio remote control SRC



**Reduced sound level**  
 The silencer box SBB reduces the sound level of the vacuum generator and protects it from outside dirt. It can be easily mounted on the optional blower console.



**Protection against dirt**  
 The dust filter STF keeps dirt particles away from the vacuum generator and is always recommended to protect the generator. It can be cleaned quickly and easily.



**Protection against thermal overload**  
 With the motor-protection switch MSS the vacuum generator can be switched on/off and protected against overcurrent. It can be integrated into the Schmalz crane column without the need for complicated wiring and can be optionally locked.



**Secure storage**  
 The storage rack AB-JU can be used to store the JumboFlex when not in use in order to protect the lift tube and vacuum grippers.



## TECHNICAL DATA



The vacuum tube lifter JumboFlex can be configured specifically based on the requirements of each individual application due to its modular design. The technical data varies depending on the configuration and on the vacuum gripper chosen.

### Vacuum generator

- Pump with 25, 40, 50 or 67 m<sup>3</sup>/h suction capacity
- Ejector with 58 or 77 m<sup>3</sup>/h suction capacity

### Lifting unit

- Max. lifting stroke (Z) 1,500 mm or 1,800 mm
- Diameter (D) 80, 100 or 120 mm

### Vacuum gripper

- Height from 50 mm up to 100 mm

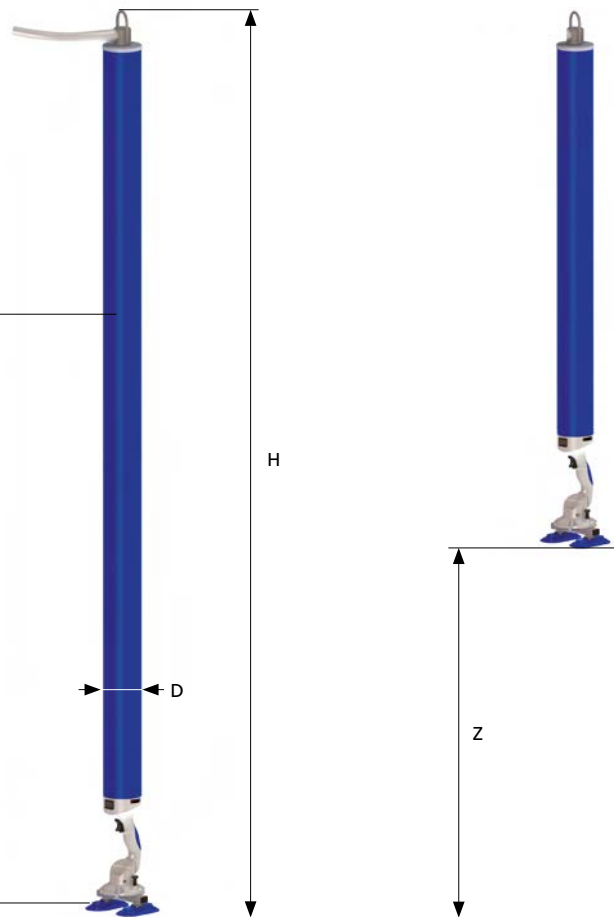

The following technical data are standard values.

Jumbo type	Max. lift capacity [kg]	Workpiece format* [mm]		Max. lifting speed [m/min]	Max. lifting stroke Z [mm]	Height H** [mm]		Lift tube Ø D [mm]
		Minimum	Maximum			With vacuum pump	With vacuum ejector	
Flex 20	20	200 x 200	2,000 x 1,000	60	1,500	2,500	2,680	80
	20	200 x 200	2,000 x 1,000	60	1,800	2,800	2,980	80
Flex 35	35	200 x 200	2,000 x 1,000	60	1,500	2,500	2,680	100
	35	200 x 200	2,000 x 1,000	60	1,800	2,800	2,980	100
Flex 50	50	200 x 200	2,000 x 1,000	60	1,500	2,500	2,680	120
	50	200 x 200	2,000 x 1,000	60	1,800	2,800	2,980	120

\*Depends on the vacuum gripper chosen

\*\*Vacuum grippers not included (total height = H + height of the vacuum gripper)



# JumboErgo and JumboSprint

Lift Capacity up to 300 kg

One modular system, two product types: The vacuum tube lifters JumboErgo and JumboSprint share a common technical basis but differ in terms of their operator handles.

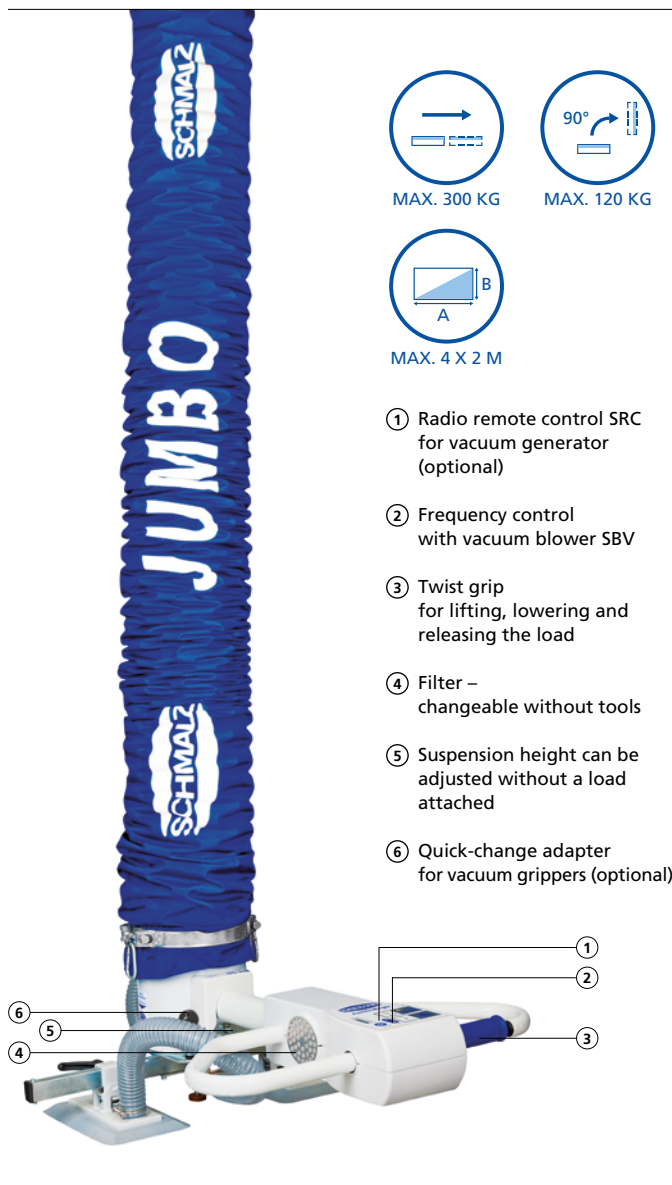

## JUMBOERGO

### For workpieces of many different shapes and sizes

The twist grip on the JumboErgo is designed to operate like a motorcycle throttle. Large and heavy loads such as wooden boards, cardboard boxes and solar panels can be moved gently and precisely. The length of the operator handle can be varied, which allows the user to always maintain a safe distance from the load.

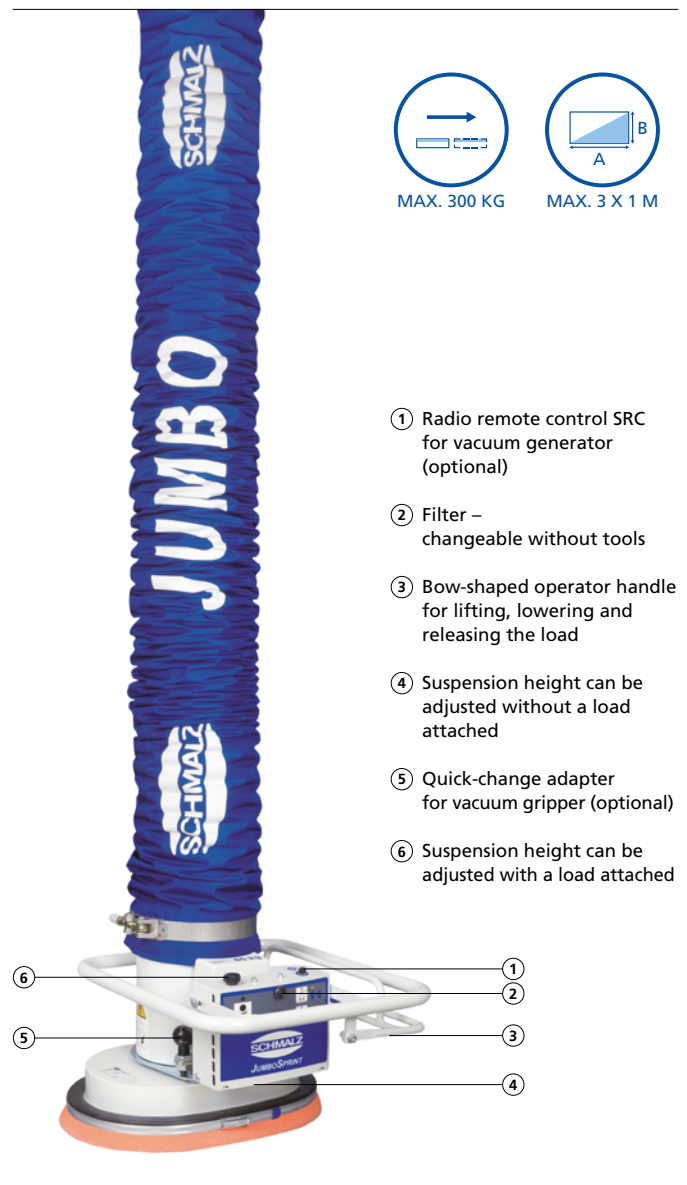

## JUMBOSPRINT

### For compact workpieces

The JumboSprint is equipped with a bow-shaped operator handle which extends all the way around the unit. This allows the user to optimally position it on compact goods such as bags or rubber bails. The load is raised by pulling up on the handle lever and lowered by pushing down.



**Quick-change adapter**  
(optional)

## VACUUM GRIPPERS

Versatility is key: Schmalz offers the right vacuum grippers for virtually any application. With the quick-change adapter the gripper can be changed quickly and easily.



**Single vacuum gripper**  
For compact goods such as cardboard boxes, barrels, buckets, jugs and cabinets.



**Single vacuum gripper, long**  
For pallets, narrow cardboard boxes, beams, square tubes and other elongated workpieces.



**Round vacuum gripper**  
For barrels, buckets or stone slabs with rough surfaces.



**Sack gripper**  
For paper and plastic bags, raw rubber bails and shrink-wrapped packages.



**Double vacuum gripper**  
For cardboard boxes, crates or sheets. The vacuum grippers can be continuously adjusted along the beam.



**Double vacuum gripper FM**  
For pallets, sections or cut pieces where the vacuum gripper is not fully covered by the workpiece. The grippers can be continuously adjusted along the beam.



**Quadruple vacuum gripper**  
For large cardboard boxes, sheets and non-rigid pieces. The vacuum grippers can be continuously adjusted lengthwise and crossways.



**Multiple vacuum gripper**  
For uneven workpieces such as foil trays or unstable cardboard boxes. The individual vacuum grippers optimally compensate for any unevenness.



**Mechanical grippers**  
Schmalz offers mechanical gripper solutions for workpieces that cannot be vacuum-gripped, such as bags or open transport boxes.

## VACUUM GENERATORS



**Blowers SBM, SBL, SBV**  
Electric vacuum generators for workpieces weighing up to 300 kg. The frequency-controlled blower SBV is continuously variable and its power can be adjusted to changing loads.



**Ejector SEM**  
Compact, compressed air vacuum generator with high flow rate for workpieces weighing up to 85 kg.

# JumboErgo and JumboSprint

## ACCESSORIES



SRC

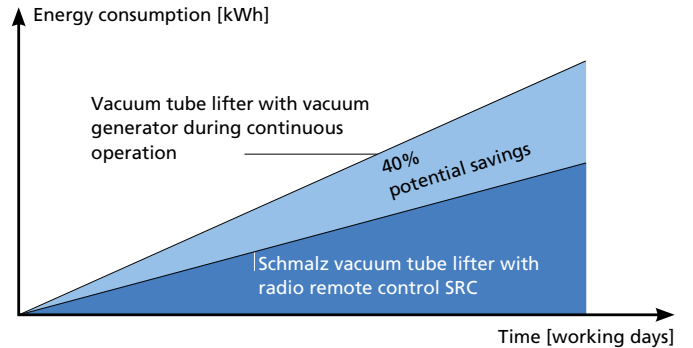

Potential energy savings with radio remote control SRC

**Save up to 40% in energy with the push of a button**  
 With the radio remote control SRC, you can directly switch off the vacuum generator on the operator handle when not in use and then back on again. The radio remote control is activated by a simple button push and needs no energy source due to an integrated solar cell.



**Swivel workpieces by 90°**  
 With the push of a button, the pneumatic swiveling unit PSE allows the user to swivel workpieces weighing up to 120 kg securely and in an ergonomic fashion.

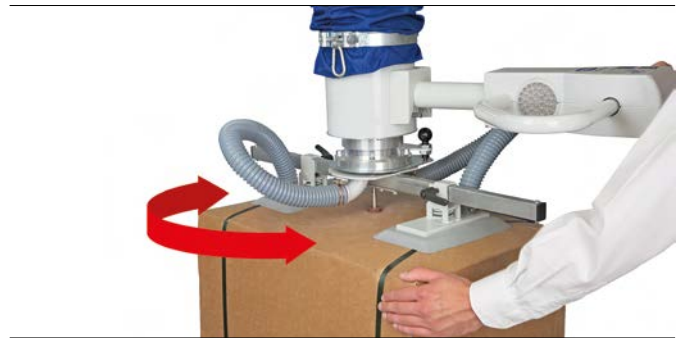

**Continuously rotate workpieces**  
 With the rotation unit DE, gripped workpieces weighing up to 200 kg can be continuously rotated and positioned precisely.



**Maximize stack heights**  
 High stacking heights are no problem with the movable operator handle (only for JumboErgo). An optional locking mechanism allows it to be fixed at different angles.



**Instantly release workpieces**  
 The venting unit BEL allows non-porous workpieces to be released from the vacuum gripper and set down.

## ACCESSORIES



### Reduce the sound level

The silencer box SBB reduces the sound level of the vacuum generator and protects it from outside dirt. It can be easily mounted on the optional blower mounting platform.



### Protection against dirt

The dust filter STF keeps dirt particles away from the vacuum generator and is always recommended to protect the generator. An optional differential pressure monitor with a signal lamp indicates when the dirty filter has to be changed.



### Reach into deep containers

The hose-cylinder extension SZV enables ergonomic loading and unloading of containers such as lattice boxes.



### Protection against thermal overload

With the motor-protection switch MSS the vacuum generator can be switched on/off and protected against overcurrent. It can be integrated into the Schmalz crane column without the need for complicated wiring and can be optionally locked.



### Spring balancer for long operator handles

The spring balancer FZG keeps the tube lifter JumboErgo balanced and is recommended if the operator handle is longer than 750 mm.



### Protection against wear

The protective tube prevents mechanical damage to the lift tube and is easy to clean. The retaining net protects the vacuum grippers and the lift tube when the tube lifter is not in use and allows for space-saving storage.

# JumboErgo and JumboSprint

## Technical Data



The vacuum tube lifters JumboErgo and JumboSprint can be configured specifically based on the requirements of each individual application due to their modular design. The technical data varies depending on the configuration and on the vacuum gripper chosen.

### Vacuum generator

- Blower with 155, 185 or 220 m³/h suction capacity
- Ejector with 132 m³/h suction capacity

### Lifting unit

- Max. lifting stroke (Z) 1,700 mm or 2,100 mm
- Diameter (D) 120 mm up to 305 mm

### Operator handle

Operator handle length (L)

- JumboErgo: 350 mm up to 1,000 mm
- JumboSprint: 155 mm up to 500 mm

### Vacuum gripper

Height around 80 mm up to 155 mm

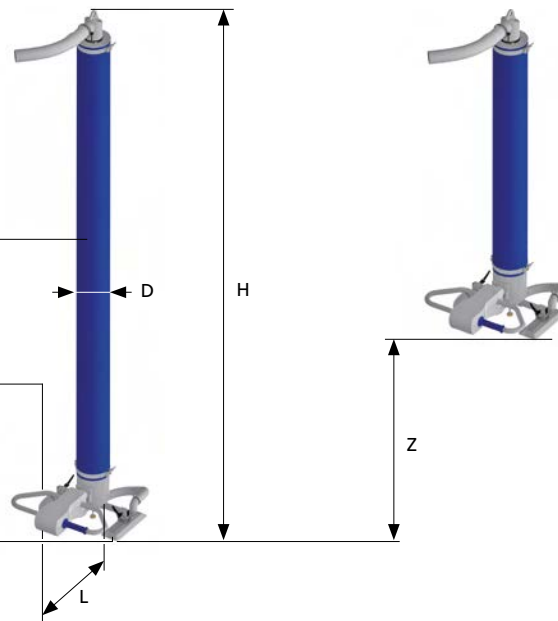
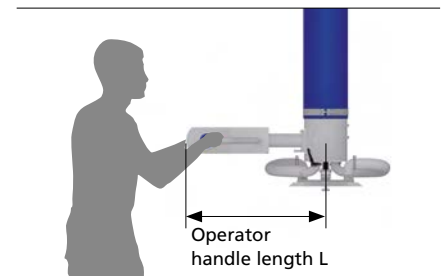

Fig. shows JumboErgo

The following technical data are standard values.

Type	Workpiece format* [mm]		Operator handle length L [mm]	Max. lifting speed [m/min]	Max. lifting stroke Z [mm]	Height H** [mm]
	Maximum	Maximum				
JumboErgo	300 x 200	4,000 x 2,000	350 – 1,000	60	1,700	2,850
	300 x 200	4,000 x 2,000				
JumboSprint	300 x 200	3,000 x 1,000	155 – 500	60	1,700	2,850
	300 x 200	3,000 x 1,000				



A lift capacity of 140 kg and higher applies: lifting stroke Z +160 mm, height H +250 mm

\*Depends on the vacuum gripper chosen

\*\*Vacuum gripper not included (total height = H + height of the vacuum gripper)

The operator handle for the JumboErgo is designed with safety in mind, allowing the operator to maintain a safe distance when oversized workpieces are being lifted.

## LIFT CAPACITIES

Jumbo type	Max. lift capacity [kg]		Ø Lift tube D [mm]	Max. lift capacity							
	Horizontal	90° swivel		35 kg	45 kg	65 kg	85 kg	110 kg	140 kg	200 kg	300 kg
Ergo/Sprint 35	35	–	120	→							
Ergo/Sprint 45	45	30	140	→	→						
Ergo/Sprint 65	65	50	160	→	→	→					
Ergo/Sprint 85	85	70	178	→	→	→	→				
Ergo/Sprint 110	110	90	203	→	→	→	→	→			
Ergo/Sprint 140	140	120	230	→	→	→	→	→	→		
Ergo/Sprint 200	200	–	250	→	→	→	→	→	→	→	
Ergo/Sprint 300	300	–	305	→	→	→	→	→	→	→	→



## JumboSprint Ex

Safe Handling in an Explosion Protection Zone

### APPLICATION

Efficient handling of loads weighing up to 250 kg in explosion protection zones

- Lifting of bags, barrels, cardboard boxes, jugs, buckets and varnish/paint containers
- Preparation and positioning of filled bags, e.g. for emptying into hoppers or mixers
- For use in explosion protection zones 1/21 and 2/22
- Certified according to ATEX 2014/34/EU standard – Can be used throughout Europe without country-specific certificate

### SPECIAL FEATURES

- Operator handle and vacuum grippers made from stainless steel
- All conductive parts are connected with a potential equalization
- Conductive lift tube made from a special material
- Vacuum generator either compressed air driven (ejector up to 85 kg) or electric (blower up to 250 kg)
- Various vacuum grippers in explosion protection design
- Easily change vacuum grippers using the quick-change adapter (optional)
- Complete system for vacuum tube lifter and steel jib crane for explosion protection zone available

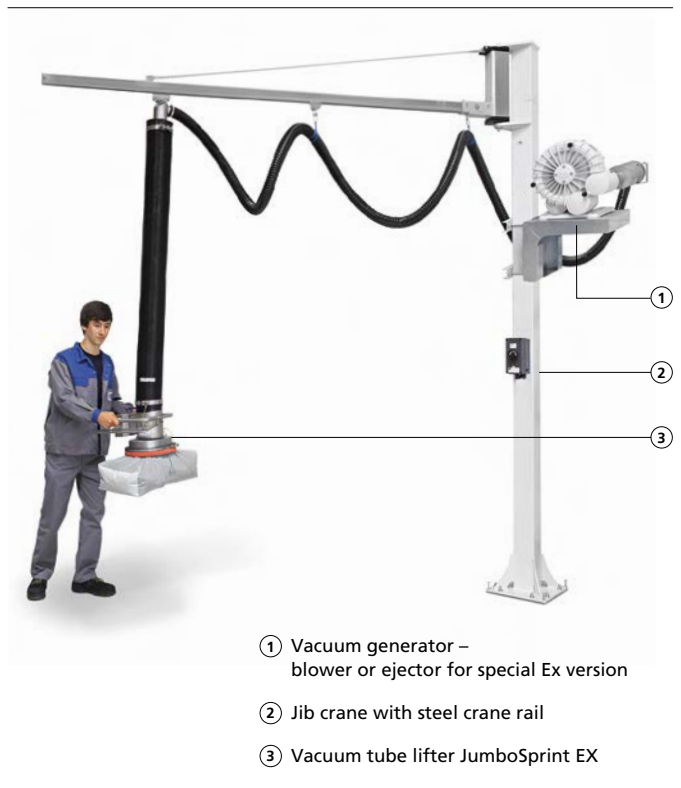

- ① Vacuum generator – blower or ejector for special Ex version
- ② Jib crane with steel crane rail
- ③ Vacuum tube lifter JumboSprint EX

### AREAS OF APPLICATION

Explosion zone	Vacuum generator	Max. lifting stroke [mm]	Max. lift capacity						
			45 kg	65 kg	85 kg	110 kg	140 kg	200 kg	250 kg
1/21	Ejector	1,700 / 2,100	▶	▶	▶				
2/22	Ejector	1,700 / 2,100	▶	▶	▶				
	Blower	1,700 / 2,100	▶	▶	▶	▶	▶	▶	▶

▶ Vacuum lifting device  
VacuMaster Basic for handling  
metal sheets

▼ Vacuum lifting device  
VacuMaster Multi, for swiveling  
wooden boards by 90°



## *Lifting Devices VacuMaster – Lighten Your Load.*

The vacuum lifting device VacuMaster from Schmalz is the ultimate workhorse. Whether handling metal plates, wooden boards, plastic sheets, barrels, windows or glass sheets – the VacuMaster tackles even the heaviest tasks with weights up to several tons. For applications where many hands would normally be required, the VacuMaster allows workpieces to be handled effortlessly by just a single operator while protecting the employee's health.



# Vacuum Lifting Devices VacuMaster

## Move Heavy Loads Weighing up to Several Tons Ergonomically

### APPLICATION

For handling large, flat and typically non-porous workpieces, for example:

- Loading and unloading CNC laser cutting machines with metal plates
- Loading and unloading CNC machining centers with wooden boards or plastic sheets
- Handling and positioning glass panels and windows during production, framing and installation

### YOUR BENEFITS

- Efficient, non-damaging handling of heavy loads
- To work ergonomically and protect operator health
- Excellent work safety and process reliability thanks to vacuum reservoir and audible warning device
- Long service life due to a robust mixture of steel, aluminum and high-strength plastic
- Low operating costs thanks to controlled vacuum generator with energy saving (Comfort version)

### DESIGN AND FUNCTION

The vacuum lifting device VacuMaster has a modular design. Various basic modules, operator handles, load beams and suction plates allow you to customize the configuration. The necessary suction force is generated by the vacuum generator and transferred to the workpiece via the suction plates. For safety purposes, the aluminum load beam also serves as a vacuum reservoir. A chain hoist is required for lifting or lowering motion, which Schmalz offers along with a compatible crane system.

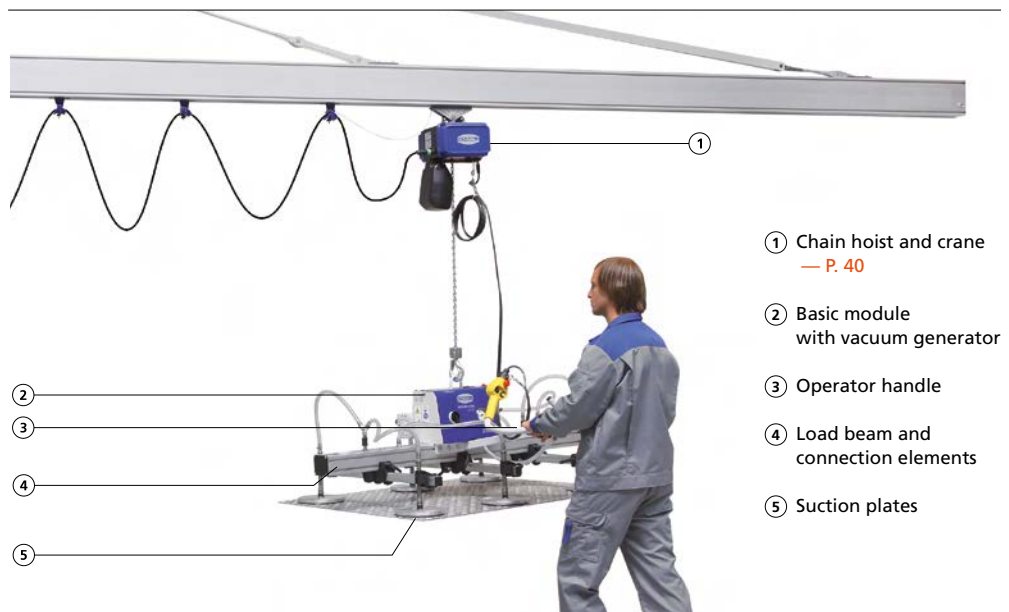

The entire system and its individual parts

### PRODUCT OVERVIEW

The right solution for any task: With their modular system, the VacuMaster Basic and VacuMaster Comfort cover standard applications weighing up to 750 kg. Schmalz also offers additional lifting devices which are specially designed for the specific requirements of certain industries.

Type	Max. lift capacity						
	100 kg	125 kg	250 kg	500 kg	1,000 kg	1,500 kg	2,000 kg
VacuMaster Horizontal	✓	✓	✓	✓	✓	✓	✓
VacuMaster 90° Swiveling	✓	✓	✓	✓	✓	✓	✓
VacuMaster 180° Turning	✓	✓	✓	✓	✓	✓	✓

--- Additional lift capacities up to more tons on request



**VacuMaster Basic and VacuMaster Comfort**  
Flexible modular system for standard applications weighing up to 750 kg  
— P. 26



**Additional VacuMaster**  
For special lift capacities and industry requirements  
— P. 32

# VacuMaster Basic and VacuMaster Comfort

Lift Capacity up to 750 kg

The VacuMaster Basic's versatile standard equipment makes it indispensable for many applications. In addition, the VacuMaster Comfort offers an operator handle that brings together all of the device's controls as well as a controlled vacuum generator for reducing energy consumption.



MAX. 750 KG

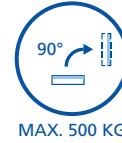

MAX. 500 KG



MAX. 500 KG

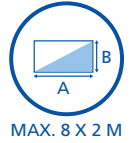

MAX. 8 X 2 M

## VACUMASTER BASIC



- ① Motor protection switch
- ② Vacuum gauge (manometer)
- ③ Vacuum on/off – picks up and releases the load via a highly reliable manual slide valve
- ④ Operator handle – Schmalz chain hoist pendant can be attached
- ⑤ Chain hoist up/down – lifts and lowers the load
- ⑥ Emergency-stop function for chain hoist

## VACUMASTER COMFORT



- ① Vacuum gauge (manometer)
- ② Integrated air-saving function
- ③ Emergency-stop function
- ④ Swivel function – continuous swiveling up to max. 90° or 180°
- ⑤ Vacuum off – secure release of the load requiring two hands
- ⑥ Chain hoist up/down – lifts and lowers the load
- ⑦ Vacuum on – picks up the load
- ⑧ Operator handle with integrated function modules for Schmalz chain hoist

## BASIC MODULE

The basic module is the heart of every VacuMaster. It contains the vacuum generator, an audible warning device as well as all the measuring and control devices. Depending on the application, you can choose from three different basic modules whose shape and design are optimally suited to the handling task.



### Horizontal handling

Standard design with vacuum generator, audible warning device, vacuum gauge (manometer) and motor protection switch. Protection of the components under a robust sheet metal barrier.

- For lift capacity up to 750 kg



### 90° swiveling

Basic version adds to electric drive for jolt-free, continuous swiveling by 90°.

- For lift capacity up to 500 kg



### 180° turning

Basic version adds to electric drive for jolt-free, continuous turning by 180°.

- For lift capacity up to 500 kg

## VACUUM GENERATORS



### Pump EVE

Electric vacuum generator for smooth and suction-tight workpieces weighing up to 750 kg.



### Ejector SEM

Compressed air vacuum generator with high flow rate for porous workpieces weighing up to 250 kg. Only for horizontal handling.



## MANUAL SLIDE VALVE

### Reliable and safe vacuum control

VacuMaster Basic with manual slide valve for high safety by double actuation and anti-trap protection. Prevents unwanted losing of the load.

## LOAD BEAM AND CONNECTION ELEMENTS



### Light, robust and flexible

The combination of aluminum and high-strength plastic allows the cross beams and suction plates to be easily adjusted to quickly adapt to changing formats.



### Integrated vacuum reservoir

The large vacuum reservoir prevents the load from falling in the case of a power failure and makes gripping faster during repeated lifting processes.

## SUCTION PLATES



### Versatility for every task

Allows for optimal adaptation to the workpiece and to requirements such as heat resistance, food safety and mark-free gripping. Select from suspension which is rigid, spring-mounted or both flexible and spring-mounted.

# VacuMaster Basic and VacuMaster Comfort

## ACCESSORIES

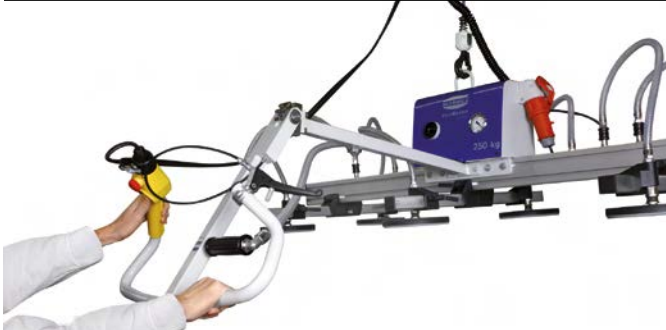

### Maximize stack heights

Large height differences are no problem with the swiveling and locking operator handle. The working posture remains ergonomic in any position.



### Adapts to changing workpieces

With the vacuum gripper shut-off valve several vacuum grippers can be turned off for handling of cut pieces or pieces with gaps.



### Secure storage of the lifting device

When the lifting device is not in use, the parking stands allow it to be stored securely while protecting the suction plates. This allows the crane to be used for other purposes.



### Quick-connect electrical connection

The CEE plug allows the lifting device to be easily connected to the power supply and then quickly disconnected if necessary (only for VacuMaster Basic).



### Mark-free handling

The suction plate covers prevent the plates from leaving marks on sensitive workpieces such as glass sheets or solar panels.



### Protection against water

The maintenance-free water separator prevents water from entering the vacuum generator during moist processes such as waterjet cutting.

## TECHNICAL DATA



Thanks to their modular system, the VacuMaster Basic and VacuMaster Comfort can be custom configured for any application. The technical data of the devices are dependent on the selected configuration. You can use the following data on pre-configured lifting devices for standard workpiece formats as a guide for determining the recommended values for your VacuMaster. **Proceed as Follows:**

**1** Select type of handling  
e.g. horizontal handling

**2** Select lift capacity  
e.g. 250 kg

**3** Select workpiece format  
e.g. 2,000 x 1,000 mm



### HORIZONTAL HANDLING

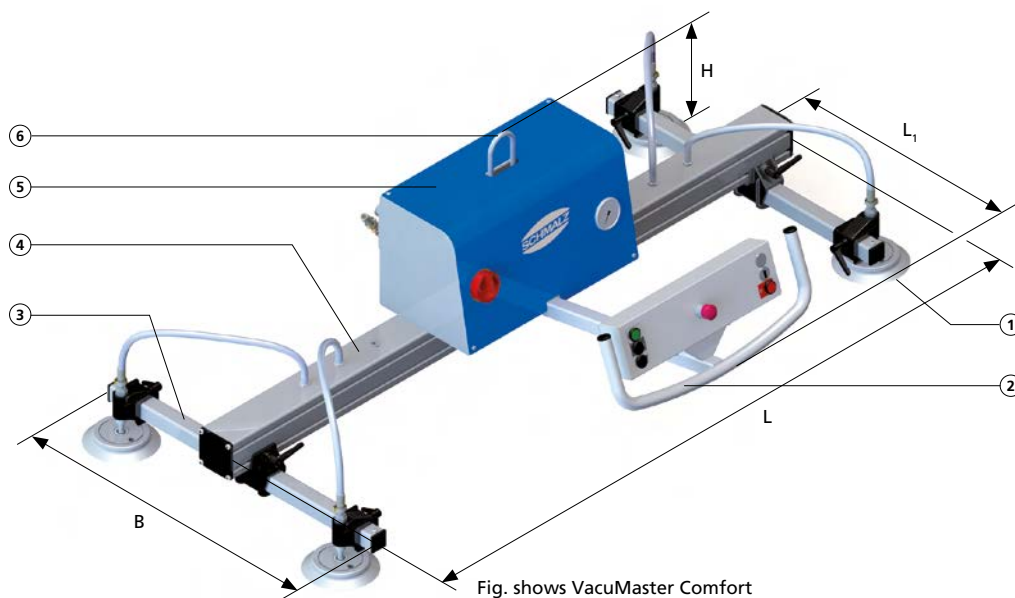

- ① Suction plates, diameter 125 mm up to 360 mm
- ② Operator handle (L<sub>1</sub>) 345 mm up to 1,060 mm
- ③ Cross beams (B) 400 mm up to 1,500 mm
- ④ Main beam (L) 800 mm up to 6,400 mm
- ⑤ Basic module with vacuum generator, vacuum pump with 4, 8, 16, 25 m<sup>3</sup>/h suction capacity, vacuum ejector with 58 m<sup>3</sup>/h suction capacity
- ⑥ Eye for chain hoist, diameter 52 mm

VacuMaster type* Max. lift capacity [kg]	Workpiece format [mm]	Dimensions L x B (length x width) [mm]	Overall height H [mm]		Operator handle L <sub>1</sub> [mm]	Suction plates**		Weight [kg]	
			Basic	Comfort		No.	Ø [mm]	Basic	Comfort
Basic/Comfort 125	1,000 x 1,000	800 x 750	490	445	655	1	250	38	42
	2,000 x 1,000	1,600 x 750	410	445	645	2	210	42	50
	2,500 x 1,250	1,600 x 750	490	525	745	4	125	52	64
	3,000 x 1,500	2,400 x 1,150	555	590	945	6	125	62	68
	4,000 x 2,000	3,200 x 1,500	555	590	1,045	8	125	80	88
Basic/Comfort 250	1,000 x 1,000	800 x 750	490	445	655	1	360	40	45
	2,000 x 1,000	1,600 x 750	410	445	645	2	250	44	52
	2,500 x 1,250	1,600 x 750	490	525	745	4	210	54	62
	3,000 x 1,500	2,400 x 1,150	555	590	945	6	160	59	67
	4,000 x 2,000	3,200 x 1,500	555	590	1,045	8	125	80	88
Basic/Comfort 500	2,500 x 1,250	1,600 x 750	570	605	760	4	250	71	84
	3,000 x 1,500	2,400 x 1,150	635	670	960	6	210	88	91
	4,000 x 2,000	3,200 x 1,500	635	670	1,060	8	210	106	130
Basic/Comfort 750	3,000 x 1,500	2,400 x 1,150	635	670	960	6	250	91	105
	4,000 x 2,000	3,200 x 1,500	635	670	1,060	8	210	115	122

\*The shown VacuMaster are example configurations: The VacuMaster Basic/Comfort can be adapted flexibly to individual workpiece formats.

\*\*The indicated number of suction plates is possible for handling of rigid goods. For unstable and thin workpieces the numbers of suction plates will be increased.



# VacuMaster Basic and VacuMaster Comfort

## Technical Data

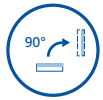

90° SWIVELING

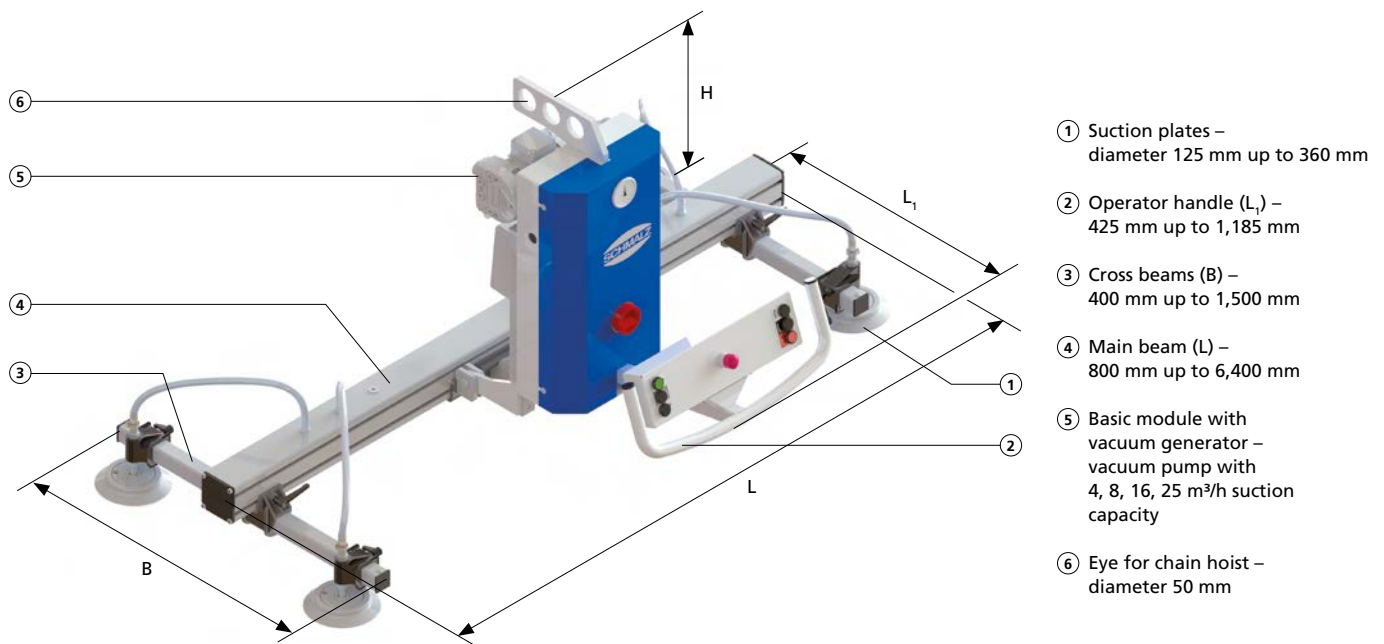

- ① Suction plates – diameter 125 mm up to 360 mm
- ② Operator handle ( $L_1$ ) – 425 mm up to 1,185 mm
- ③ Cross beams (B) – 400 mm up to 1,500 mm
- ④ Main beam (L) – 800 mm up to 6,400 mm
- ⑤ Basic module with vacuum generator – vacuum pump with 4, 8, 16, 25 m<sup>3</sup>/h suction capacity
- ⑥ Eye for chain hoist – diameter 50 mm

Fig. shows VacuMaster Comfort

VacuMaster type* Max. lift capacity [kg]	Workpiece format [mm]	Dimensions L x B (length x width) [mm]	Overall height H [mm]		Operator handle $L_1$ [mm]	Suction plates**		Weight [kg]	
			Basic	Comfort		No.	Ø [mm]	Basic	Comfort
Basic/Comfort 125	2,000 x 1,000	1,600 x 750	720	720	725	2	360	74	76
	2,500 x 1,250	1,600 x 750	800	800	725	4	210	79	81
	4,000 x 2,000	3,200 x 1,500	800	800	1,025	8	210	94	101
Basic/Comfort 250	2,500 x 1,250	1,600 x 750	800	800	725	4	360	91	93
	4,000 x 2,000	3,200 x 1,500	800	800	1,025	8	210	102	104
Basic/Comfort 500	2,500 x 1,250	1,600 x 750	1,030	1,030	785	4	360	135	137
	4,000 x 2,000	3,200 x 1,500	1,030	1,030	1,085	8	360	151	153

\*The shown VacuMaster are example configurations: The VacuMaster Basic/Comfort can be adapted flexibly to individual workpiece formats.

\*\*The indicated number of suction plates is possible for handling of rigid goods. For unstable and thin workpieces the numbers of suction plates will be increased.



## 180° TURNING

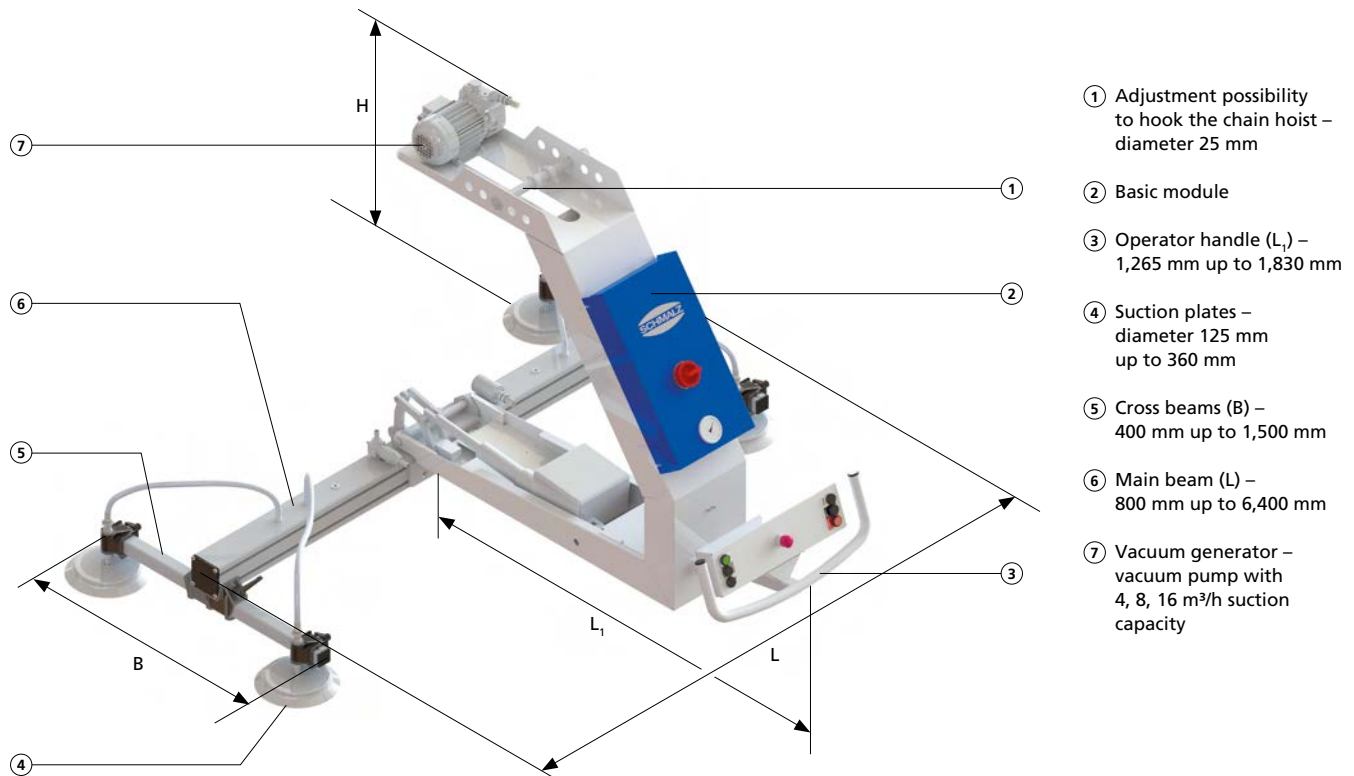

- ① Adjustment possibility to hook the chain hoist – diameter 25 mm
- ② Basic module
- ③ Operator handle (L<sub>1</sub>) – 1,265 mm up to 1,830 mm
- ④ Suction plates – diameter 125 mm up to 360 mm
- ⑤ Cross beams (B) – 400 mm up to 1,500 mm
- ⑥ Main beam (L) – 800 mm up to 6,400 mm
- ⑦ Vacuum generator – vacuum pump with 4, 8, 16 m<sup>3</sup>/h suction capacity

Fig. shows VacuMaster Comfort

VacuMaster type* Max. lift capacity [kg]	Workpiece format [mm]	Dimensions L x B (length x width) [mm]	Overall height H [mm]		Operator handle L <sub>1</sub> [mm]	Suction plates**		Weight [kg]	
			Basic	Comfort		No.	Ø [mm]	Basic	Comfort
Basic/Comfort 75	1,000 x 1,000	800 x 750	1,150	1,150	1,265	2	250	74	74
	2,000 x 1,000	1,600 x 750	1,150	1,150	1,265	2	250	82	82
	2,500 x 1,250	1,600 x 750	1,220	1,220	1,265	4	210	92	92
Basic/Comfort 125	2,000 x 1,000	1,600 x 750	1,160	1,160	1,265	2	360	87	87
	2,500 x 1,250	1,600 x 750	1,230	1,230	1,265	4	210	92	92
Basic/Comfort 250	2,000 x 1,000	1,600 x 750	1,770	1,770	1,830	4	360	137	139
	2,500 x 1,250	1,600 x 750	1,750	1,750	1,830	8	210	145	147
	4,000 x 2,000	3,200 x 1,500	1,750	1,750	1,830	8	210	165	167

\*The shown VacuMaster are example configurations: The VacuMaster Basic/Comfort can be adapted flexibly to individual workpiece formats.

Technical data for VacuMaster Basic/Comfort 500 on request.

\*\*The indicated number of suction plates is possible for handling of rigid goods. For unstable and thin workpieces the numbers of suction plates will be increased.



VacuMaster Vario in process of loading and unloading a laser cutting machine



UNIVERSAL



MAX. 2000 KG

## VacuMaster Vario

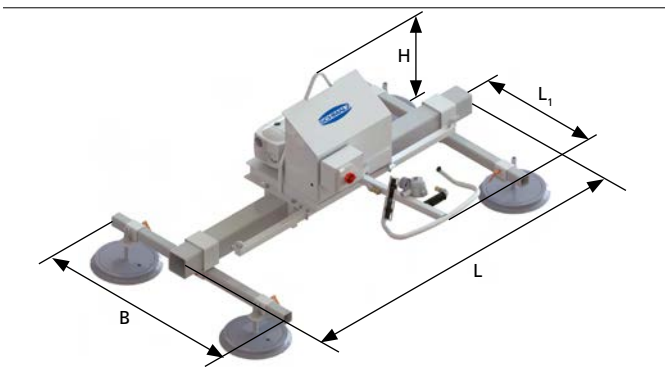

Design of VacuMaster Vario



Special VacuMaster Vario with lift capacity of 10 t  
(special applications with lift capacity over 2 t on request)

### APPLICATION

Horizontal handling of especially heavy, airtight workpieces weighing up to 2,000 kg

- Loading and unloading machines with large-format metal sheets and plates
- Solutions for heavier loads are also possible, e.g. lifting devices for handling rotor blades weighing several tons and up to 60 m in length

### DESIGN AND FUNCTION

- Modular vacuum lifting device with ergonomic operator handle
- Highly reliable manual slide valve to turn on/off the vacuum
- Electric vacuum pump for short evacuation times
- Robust steel load beam
- Audible warning device and vacuum reservoir for redundant safety in loss of vacuum and power failure respectively
- Large selection of suction plates

### YOUR BENEFITS

- Heavy loads are handled very securely
- Simple adaption to the individual application

VacuMaster type	Max. lift capacity* [kg]	Workpiece format [mm]		Dimensions [mm]		Overall height H [mm]	Operator handle L <sub>1</sub> [mm]	Number of suction plates	Weight [kg]
		Minimum	Maximum	L (length)	B (width)				
Vario 1000	1,000	900 x 520	6,000 x 2,000	2,000 – 4,000	1,150	630 – 935	910 – 1,250	1, 4, 8	116 – 252
Vario 2000	2,000	1,230 x 900	6,000 x 2,000	2,000 – 4,000	1,150	820 – 1,000	910 – 1,250	2, 4, 8	231 – 345

\*Higher lift capacities available on request.





VacuMaster Eco for removing steel sheets from a drawer shelving system



UNIVERSAL

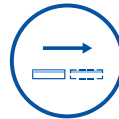

MAX. 1000 KG

## VacuMaster Eco

### APPLICATION

Horizontal handling of smooth and airtight workpieces without an external energy source

- For example metal sheets/plates, barrels and stone slabs

### DESIGN AND FUNCTION

- Modular vacuum lifting device with piston system for vacuum generation without energy
- Vacuum is established/dissipated by the lifting/lowering motion of the chain hoist (chain hoist not included)
- Aluminum load beam with integrated vacuum distributor (up to 750 kg lift capacity)
- Battery-operated warning device with battery test function for warning of fallen vacuum
- Easily adjustable vacuum grippers

### YOUR BENEFITS

- Secure and gentle vacuum handling
- Energy independence allows for flexibility in use
- Quick installation and start of operations
- Minimal operating costs

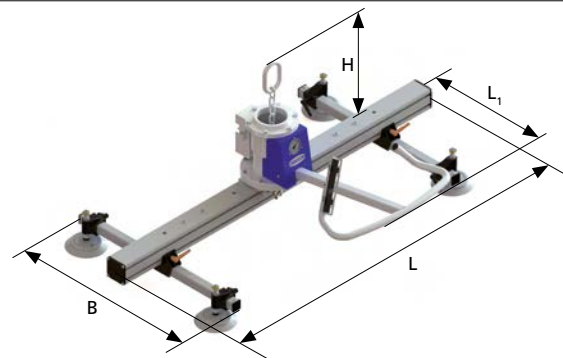

Design of VacuMaster Eco

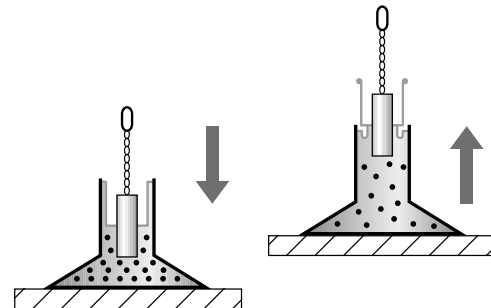

Functional principle of VacuMaster Eco

VacuMaster type	Max. lift capacity* [kg]	Workpiece format [mm]		Dimensions [mm]		Overall height H [mm]	Operator handle L <sub>1</sub> [mm]	Number of suction plates	Weight [kg]
		Minimum	Maximum	L (length)	B (width)				
Eco 75	75	220 x 220	1,000 x 1,000	210	210	368 – 382	–	1	8
Eco 250	250	360 x 360	3,000 x 2,000	800 – 2,400	400 – 1,500	450 – 825	400 – 1,100	1, 2, 4, 6, 8	33 – 59
Eco 500	500	480 x 480	4,000 x 2,000	800 – 3,200	400 – 1,500	605 – 1,130	500 – 1,200	1, 2, 4, 6, 8	93 – 141
Eco 750	750	900 x 620	4,000 x 2,000	800 – 3,200	400 – 1,500	735 – 1,130	500 – 1,200	4, 6, 8	132 – 141
Eco 1000	1,000	630 x 630	4,000 x 2,000	800 – 4,000	1,150	730 – 1,210	500 – 1,200	1, 4, 8	138 – 309

\*The recommended minimum workpiece weight is 10% of the lift capacity.



VacuMaster Window for rotating and palletizing windows



GLASS



MAX. 300 KG

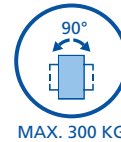

MAX. 300 KG

## VacuMaster Window

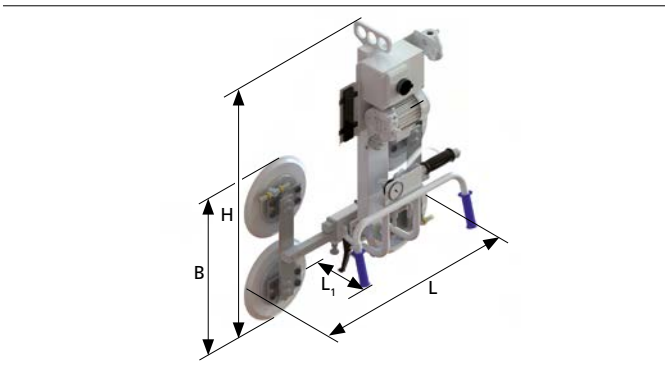

Design of VacuMaster Window

### APPLICATION

Vertical handling of windows, glass sheets and glass components

- For windows with sash parts or frames protruding up to 45 mm
- Workpieces can be rotated by 90° (3,000 mm maximum workpiece diameter for rotating)

### DESIGN AND FUNCTION

- Operator handle with manual slide valve to turn on/off the vacuum
- Electric vacuum pump for short evacuation times
- Manual rotation unit, up to 90° left or right
- Audible warning device and vacuum reservoir for redundant safety in loss of vacuum and power failure respectively
- UV and ozone-resistant suction plates



VacuMaster Window Comfort

### VacuMaster Window Comfort

- Same basic features as VacuMaster Window
- Operator handle with integrated control of all functions (see page 26)
- Air-saving function to reduce energy consumption
- Electric rotation unit for one-directional motorized rotation through 90° (optional)

### YOUR BENEFITS

- Secure handling of glass while leaving no marks
- Increase in productivity due to faster turnover
- Effortless rotation of workpieces
- Small basic body for a good view

VacuMaster type	Max. lift capacity [kg]	Workpiece format [mm]		Dimensions [mm]		Overall height H [mm]	Operator handle L <sub>1</sub> [mm]	Suction plates		Weight [kg]	Rotation mechanism
		Minimum	Maximum	L (length)	B (width)			No.	Ø [mm]		
Window 200	200	320 x 630	2,000 x 2,000	630–930	300	920	390	2	300	39	Manual, left/right
Window 300	300	630 x 630	2,000 x 2,000	630–930	630	1,090	400	4	300	55	Manual, left/right
Window Comfort 200	200	320 x 630	2,000 x 2,000	630–930	300	920	550	2	300	55	Manual, left/right
Window Comfort 200 EL	200	320 x 630	2,000 x 2,000	630–930	630	920	570	2	300	71	Electric, right
Window Comfort 300	300	630 x 630	2,000 x 2,000	630–930	300	1,090	630	4	300	59	Manual, left/right
Window Comfort 300 EL	300	630 x 630	2,000 x 2,000	630–930	630	1,090	650	4	300	76	Electric, right



VacuMaster Multi for swiveling wooden boards by 90°



WOOD



MAX. 400 KG

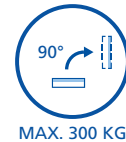

MAX. 300 KG

## VacuMaster Multi

### APPLICATION

Handling large, heavy wooden boards, either airtight or porous

- Rough and coated MDF, OSB and particle boards
- Also for gypsum fiber and gypsum plaster board as well as plastic sheets
- 90° swiveling of workpieces (optional)

### DESIGN AND FUNCTION

- Vacuum lifting device with movable operator handle to adjust the working height
- High-power vacuum blower with centrifugal mass to delay vacuum dissipation in event of a power failure
- Audible warning device
- Reversing valve to quickly release the load
- Electric drive for continuous and precise swiveling through 90° (optional)
- Large suction plates which can be shifted the main beam

### YOUR BENEFITS

- Work ergonomically at any working height
- Porous workpieces are handled very securely
- Robust design for use in harsh working environments
- Precise, continuous swiveling (optional)
- Large volume for highly porous workpieces

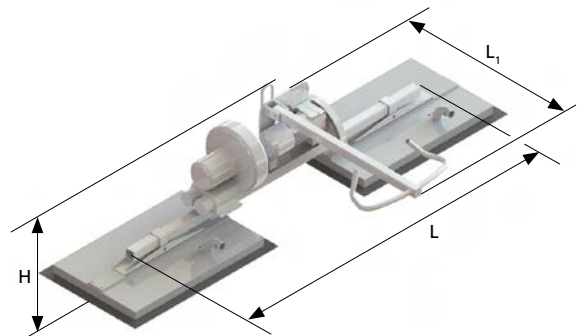

Design of VacuMaster Multi

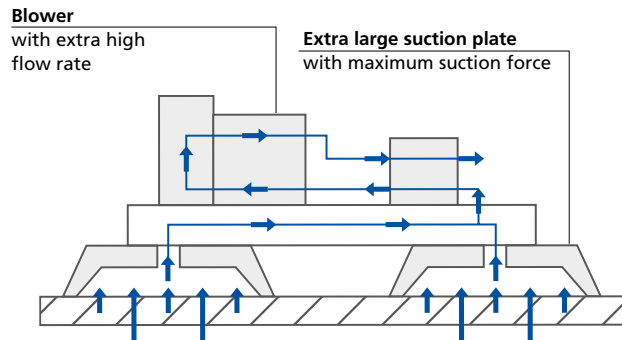

Functional principle of VacuMaster Multi for picking up large and porous plates

VacuMaster type	Max. lift capacity [kg]		Workpiece format [mm]		Main beam length L [mm]	Overall height H [mm]	Operator handle L <sub>1</sub> [mm]	Suction plates		Weight [kg]
	Horizontal	Vertical	Minimum	Maximum				No.	Size [mm]	
Multi 400	400	–	1,100 x 700	4,100 x 2,100	–	520	1,050	1	1,000 x 675	80
	400	–	1,400 x 1,100	5,600 x 2,100	2,000	600	1,050	2	1,000 x 675	133
Multi 400/150 90°	400	150	1,100 x 700	4,100 x 2,100	–	540	1,050	1	1,000 x 675	101
Multi 400/300 90°	400	300	1,400 x 1,100	5,600 x 2,100	2,000	620	1,050	2	1,000 x 675	159
	400	300	2,200 x 1,000	5,600 x 2,100	2,500	630	1,050	8	Ø 400	189



VacuMaster HHVM for removing wooden boards from upright storage



WOOD



MAX. 200 KG

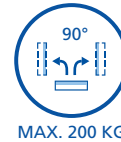

MAX. 200 KG

## VacuMaster HHVM

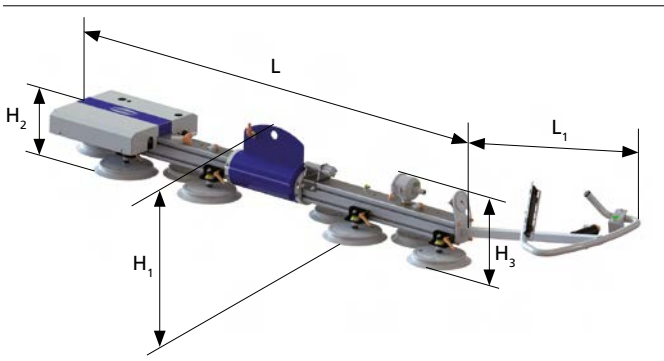

Design of VacuMaster HHVM

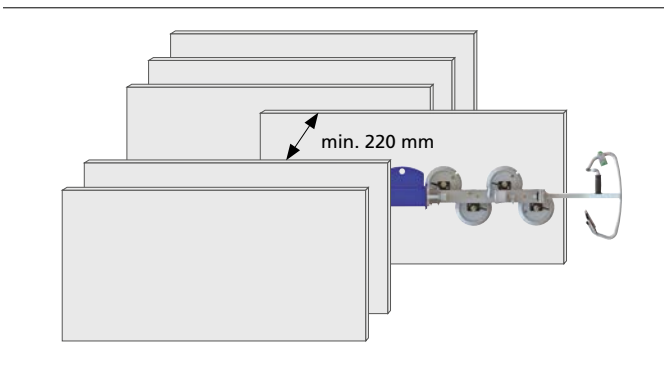

Overall height of VacuMaster HHVM when swiveled by 90°

### APPLICATION

Vertical handling of wooden boards and swiveling of workpieces by 90° from horizontal to the right or left

- For very narrow pieces such as kitchen countertops or cutting scraps
- Removing wooden boards from upright storage
- Loading and unloading vertical saws

### DESIGN AND FUNCTION

- Vacuum lifting device with flat design and front-side operator handle
- Highly reliable manual slide valve to turn on/off the vacuum
- Highly responsive pivot bearing with pneumatic latch bolt
- Pneumatic vacuum ejector with high suction flow rate
- Air-saving control to reduce energy consumption
- Audible warning device and vacuum reservoir for redundant safety in loss of vacuum and power failure respectively
- Offset suction plates available with either single or double deactivation

### YOUR BENEFITS

- Lifting and swiveling of wooden boards allows for increased productivity
- Low overall height allows it to be used in tight spaces
- Low energy consumption with high suction flow rate

VacuMaster type	Max. lift capacity [kg]	Workpiece format* [mm]		Main beam L [mm]	Overall height [mm]			Operator handle L <sub>1</sub> [mm]	Suction plates		Weight [kg]
		Minimum	Maximum		H <sub>1</sub>	H <sub>2</sub>	H <sub>3</sub>		No.	Ø [mm]	
HHVM 100	100	1,350 x 420	4,100 x 3,050	1,900	325	220	270	700	4	250	49
HHVM 150	150	1,600 x 420	4,100 x 3,050	1,900	325	220	270	700	6	250	54
HHVM 200	200	1,950 x 420	4,100 x 3,050	1,900	325	220	270	700	8	250	59

\*For swiveling large panels the suction plates need to be attached off center.



VacuMaster VHB in process of loading a rip saw with wooden boards



## VacuMaster VHB

### APPLICATION

Horizontal handling of narrow workpieces such as planks, boards and beams with a minimum width of 120 mm

- Loading rip saws

### DESIGN AND FUNCTION

- Vacuum lifting device with flat design and front-side operator handle
- Highly reliable manual slide valve to turn on/off the vacuum
- Electric vacuum pump with high suction capacity
- Audible warning device and vacuum reservoir for redundant safety in loss of vacuum and power failure respectively
- Two rectangular suction plates, can be shifted along the length of the beam
- VacuMaster VHB 350/500 with two separate suction areas including a self-locking ball valve that prevent vacuum loss by closing the vacuum feed to a particular area if there are cracks or damages on the workpiece

### YOUR BENEFITS

- Secure handling of long boards and planks
- Excellent seal on moist, unplanned and cracked wood
- Suction plates can be quickly adapted to various workpiece lengths
- Low-noise operation with low sound level

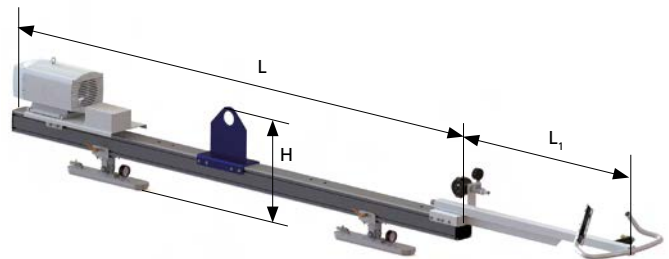

Design of VacuMaster VHB

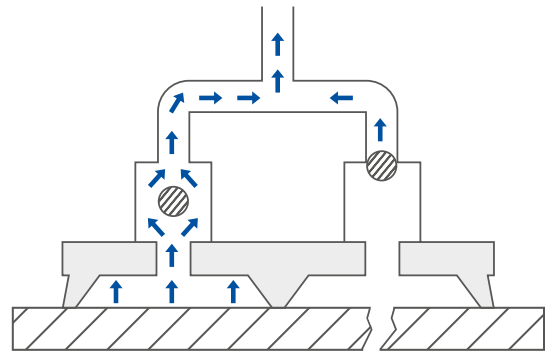

Suction plate with two separate suction areas and self-locking ball valves of the VacuMaster VHB 350/500

VacuMaster type	Max. lift capacity [kg]		Workpiece format [mm]		Main beam length L [mm]	Overall height H [mm]	Operator handle L <sub>1</sub> [mm]	Suction plate		Weight [kg]
	Full coverage	Partial coverage	Minimum	Maximum				No.	Size [mm]	
VHB 250	250	–	120 x 1,200	1,000 x 6,000	3,210	550	1,220	2	550 x 100	100
VHB 500	500	–	220 x 1,200	1,000 x 6,000	3,210	550	1,220	2	550 x 200	145
VHB 350/500	500	350	220 x 1,200	1,000 x 6,000	3,210	550	1,220	2	550 x 200	145



VacuMaster Coil for swiveling stainless steel coils by 90°



METAL



MAX. 1000 KG

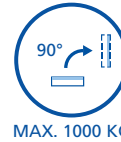

MAX. 1000 KG

## VacuMaster Coil

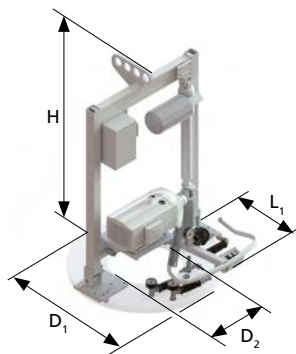

Design of VacuMaster Coil

### APPLICATION

Handling coils and slit strip, e.g. for positioning onto a decoiler mandrel

- For thin and ultra-thin sheet metal, steel and stainless steel, metal foils, tinplate and aluminum
- Maximum strip thickness of 3.0 mm (aluminum) or 1.5 mm (steel)
- Continuous swiveling up to 90°

### DESIGN AND FUNCTION

- Vacuum lifting device with vacuum clamps (suction rings) that can be switched on/off separately
- Highly reliable manual slide valve for activating vacuum
- Electric vacuum pump for short evacuation times
- Precise electric drive for continuous swiveling of the load
- Audible warning device and vacuum reservoir for redundant safety in loss of vacuum and power failure respectively
- Transparent suction plate for easily positioning



Suction plate with three separate vacuum clamps

### YOUR BENEFITS

- Different sized coils can be handled with one device
- Exact positioning and safe gripping of coils
- Damage-free gripping without mechanical clamping
- Loads can be swiveled effortlessly and set down flush with the floor

VacuMaster type	Max. lift capacity [kg]	Workpiece format Ø [mm]		Max. coil height At		Overall height H [mm]	Operator handle L <sub>1</sub> [mm]	Suction plate Ø [mm]		Number of suction clamps	Weight [kg]
		Minimum	Maximum	50 Hz	60 Hz			Inner D <sub>1</sub>	Outer D <sub>2</sub>		
Coil 500 90°	500	600	1,200	400	330	1,300	660	410	850	3	140
Coil 750 90°	750	600	1,400	220	160	1,300	660	410	1,050	3	155
Coil 1000 90°	1,000	750	1,800	320	240	1,300	660	410	1,200	3	190



VacuMaster Light for handling metal housings



## VacuMaster Light

### APPLICATION

Horizontal handling of mainly airtight small to medium-sized workpieces weighing up to 100 kg

- For example, metal plates, plastic sheets, barrels, cabinets, furniture parts or sections
- Its versatility allows it to be used in processes such as component assembly, packaging and machine loading

### DESIGN AND FUNCTION

- Compact and light vacuum lifting device
- Pneumatic vacuum ejector with high suction capacity
- Central control button for vacuum control
- Choose between one large suction plate or four hinged pad mounting arms that are flexible and continuously adjustable

### YOUR BENEFITS

- Ergonomic operation and low weight allow you to work for long periods without fatigue
- Vacuum grippers can be adjusted quickly and easily to handle different workpieces
- Quick and easy installation and startup

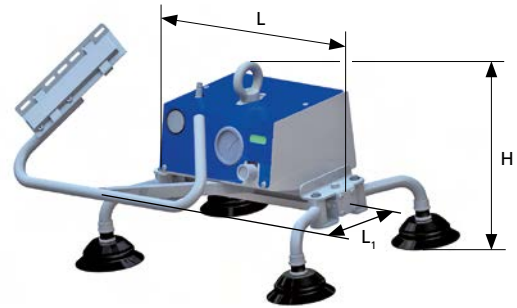

Design of VacuMaster Light

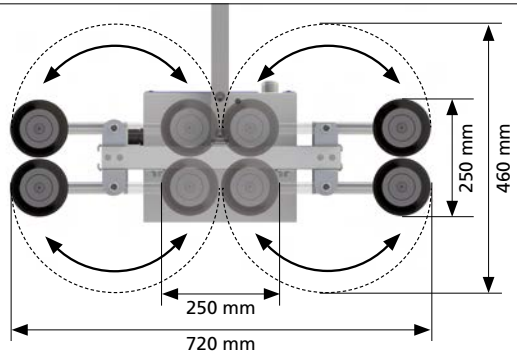

VacuMaster gripper spacing with adjustable suction feet (VacuMaster Light 100-4)

VacuMaster type	Max. lift capacity [kg]	Workpiece format [mm]		Length L [mm]	Overall height H [mm]	Operator handle L <sub>1</sub> [mm]	Suction plates		Weight [kg]
		Minimum	Maximum				No.	Ø [mm]	
Light 100-1	100	250 x 250	1,500 x 800	260	270	405	1	250	15
Light 100-4	100	250 x 250	2,000 x 800	400	330	405	4	120	15

- ▶ Aluminum crane system SRA with a chain hoist
- ▼ Wall-mounted jib crane WK with vacuum tube lifter Jumbo

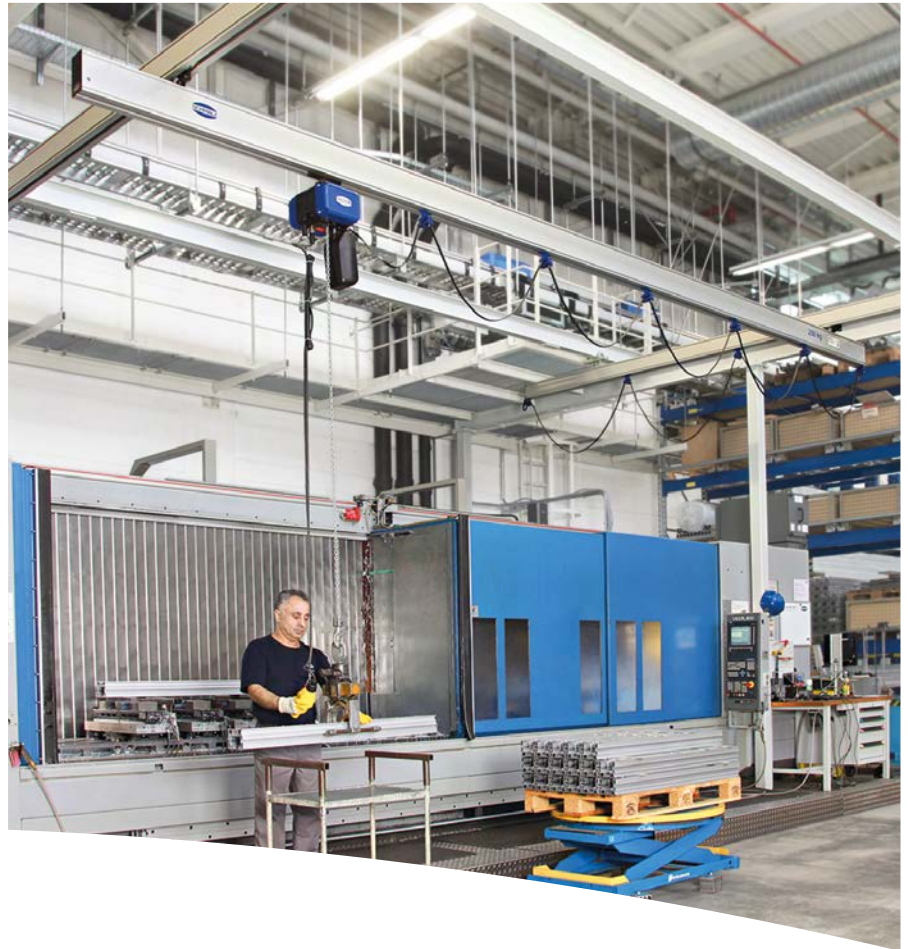

## *Crane Systems – The Easy Way.*

We have drawn on all of our experience and expertise as system manufacturers to create our Schmalz crane systems. Thanks to their consistently lightweight design, they are the perfect addition to your vacuum tube lifter Jumbo or vacuum lifting device VacuMaster. Whether as a jib crane or a crane system, the Schmalz modular system enables perfect integration into your working environment. Even as a stand-alone solution, the modern crane system provides numerous advantages for your benefit.



# Aluminum Crane Systems

Lift Capacity up to 1,200 kg



Aluminum crane system SRA with a chain hoist and vacuum lifting device VacuMaster



Aluminum crane system SRA with vacuum tube lifter Jumbo

## APPLICATION

Flexible modular system for the assembly of individual crane solutions

- Used in nearly all in-house handling and logistics processes

## YOUR BENEFITS

- Optimally adjustable to the nominal lift capacity of the tube lifter or lifting device
- Outstanding low-friction operation and low moving mass
- High-quality wear-resistant components
- Modern design with anodized surfaces
- Speeds up working processes and enables high-precision positioning
- Supports ergonomic operation while reducing strain on workers



Aluminum crane sections SRA

## DESIGN AND FUNCTION

- Crane runway and crane girder made of aluminum sections SRA
- Extremely resistant to bending and torsion forces
- Can be configured as a single-girder, double-girder or monorail crane system
- Several crane girders (bridges) can be used in one crane system
- Crane runways can be extended as needed using rail connectors; also for existing cranes
- Optimized energy supply
- Easy to install on a ceiling or portal construction using rigid or height-adjustable suspension elements
- Flexible adjustable working area with variable end stops

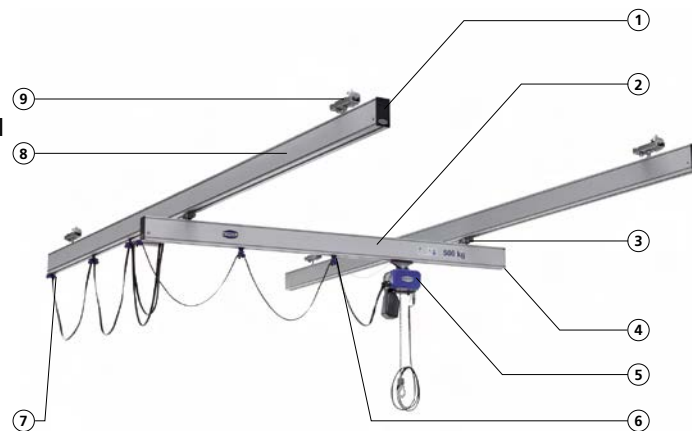

- ① End plate
- ② Crane girder made of aluminum crane section SRA
- ③ Transport trolley, fork versions
- ④ End stops, 1x fixed and 1x adjustable
- ⑤ Chain hoist
- ⑥ Cable trolley for the energy supply
- ⑦ Terminal clamp for the energy supply
- ⑧ Crane runway made of aluminum crane section SRA, weighs as little as 3 kg/m
- ⑨ Suspension of the crane runway, rigid or movable, height-adjustable

# Aluminum Jib Cranes

Lift Capacity up to 1,000 kg



Column-mounted jib crane SK with chain hoist and lifting device VacuMaster



Wall-mounted jib crane WK with tube lifter Jumbo

## APPLICATION

Workplace crane solution for ergonomic and efficient handling of loads

- Available as a column-mounted or wall-mounted jib crane

## YOUR BENEFITS

- Optimally adjustable to the nominal lift capacity of the tube lifter or lifting device
- Outstanding low-friction operation and low moving mass
- High-quality wear-resistant components
- Modern design with anodized surfaces
- Speeds up working processes and enables high-precision positioning
- Supports ergonomic operation while reducing strain on workers

## DESIGN AND FUNCTION

### Column-mounted jib crane SK

- Aluminum crane rail and pivot bearing
- Steel crane column, optional with integrated motor-protection switch
- Already fitted with anchors for floor mounting without additional intermediate plates
- Optionally available with a mobile base plate for easy transport using a forklift or pallet truck

### Wall-mounted jib crane WK

- With the same jib boom as the column-mounted jib cranes
- Mounted using a wall bracket or clasp bracket (for example on a building column in a production room)

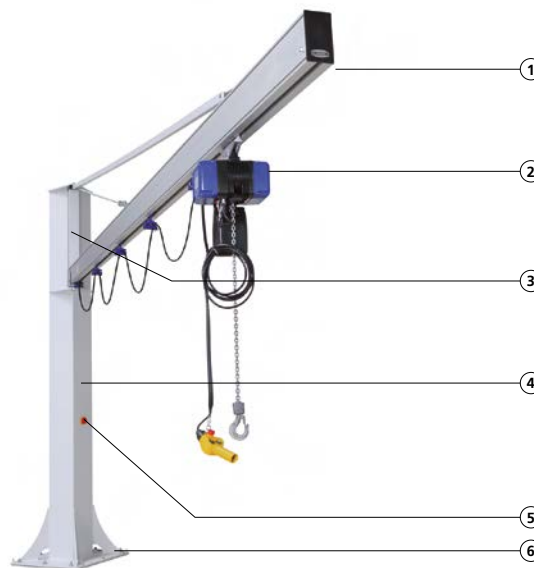

- ① Aluminum crane rail – length: 2,000 mm up to 8,000 mm
- ② Chain hoist for lifting devices VacuMaster
- ③ Aluminum pivot bearing – swivel angle of 270° (SK) / 180° (WK); can also be limited
- ④ Crane column – max. overall height: 5,000 mm lower edge of crane rail: max 4,000 mm
- ⑤ Integrated main switch
- ⑥ Base plate – fitted with anchors, 400 x 400 mm up to 950 x 950 mm

Type	Max. lift capacity												
	45 kg	65 kg	80 kg	85 kg	110 kg	125 kg	140 kg	200 kg	300 kg	350 kg	650 kg	1,000 kg	
Jib crane for Jumbo*	▶												
Universal jib crane (for use with chain hoist/VacuMaster)	▶												

\*The load classes correspond to the nominal lift capacities of the tube lifter Jumbo. The tube lifter's weight has already been taken into account.

## CRANE SOLUTIONS FOR CONFINED SPACES



**Flat jib**  
for particularly low ceilings



**Articulated-arm jib**  
to move around obstacles



**Telescopic jib**  
for confined working areas

## ACCESSORIES



Conductor line SCL

### Wireless Power Supply for Crane Systems

The conductor line SCL provides electricity to all the devices carried along with the crane, such as a chain hoist or vacuum lifting device

- There are no cable storage devices or cable loops to cause interference
- Available in five different lengths ranging from 500 to 4,000 mm (can be expanded as needed)
- UL certified

## Chain Hoists

Lift Capacity up to 2,000 kg



Chain hoist SCH

### Powerful and Durable – the Schmalz Chain Hoist SCH

Durable chain hoist with standard limit switches and phosphate-coated, case-hardened steel profile chain

- High-quality pressure-cast aluminum housing with molded cooling fins
- Plug & play connector, the chain hoist arrives ready to use
- Gearboxes with helical gearing make them responsive
- The control voltage of 42 V and the emergency-stop function ensure extremely safe operation
- Robust operator element can be put on the operator handle of the VacuMaster
- CSA certified (USA/Canada)
- Standard lifting height of 3,000 mm, optional variable chain length
- Available with optional frequency control for sensitive positioning

- ▶ System consultants in the field are happy to advise you on-site
- ▼ Experienced service technicians can perform the entire installation upon request



## *Your Project in Good Hands*

With a vacuum handling system from Schmalz, you're choosing more than just a product. We help you find a solution that allows you to work more quickly, more ergonomically, and more efficiently. Our expertise in designing and constructing systems is a result of our years of experience and the comprehensive knowledge of our employees.

# Decide

By Deciding on Schmalz, You're Choosing ...

## Maximum Safety and Reliability

Safety for the operator and process reliability are our main priorities when developing handling systems. All Schmalz products meet or surpass the currently applicable European and international safety standards:

- Consistent observation of safety factors and compliance with safety regulations
- Safe operation with warning and protective systems
- Deliberated operating concept to prevent errors during operation
- High-quality products that are "Made in Germany"
- Comprehensive service package



Safety has a high priority at Schmalz

## Working Ergonomically

Musculoskeletal disorders are the most often-cited reason for absence and sick leave from work. One cause of these disorders is lifting and carrying loads during the workday. Even when handling lighter loads, employees often move several tons per shift. For this reason, experts recommend using lifting aids for lifting and carrying even lighter loads. Vacuum handling systems from Schmalz are the perfect tools for lifting and carrying both light and heavy loads. The ergonomic working posture when using these tools is gentle on the spine and the muscles of the back, minimizing the risk of absences due to employee injuries.

Age range	Physically Reasonable Loads			
	Occasional lifting and carrying (no more than 1x per hour)		More frequent lifting and carrying (more than 2x per hour)	
	Women	Men	Women	Men
15 – 18 years old	15 kg	35 kg	10 kg	20 kg
19 – 45 years old	15 kg	55 kg	10 kg	30 kg
> 45 years old	15 kg	45 kg	10 kg	25 kg

Recommendation by the German Federal Ministry of Labour and Social Affairs for implementing the European Directive 90/269/EWG

## Increased Productivity

Vacuum handling systems from Schmalz make your working processes not only more ergonomic, but also more productive:

- Handling speeds at a consistently high level
- Reduced work-related strain increases employee motivation
- Unproductive downtimes, such as during machine loading, are reduced
- Gentle handling minimizes waste

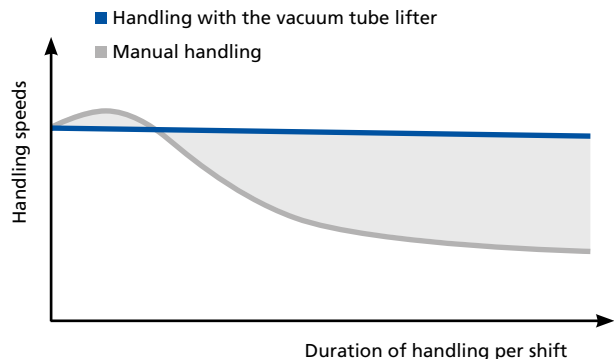



Comparison of handling speeds between handling with the vacuum tube lifter and manual handling

# Select

## Jumbo or VacuMaster?

You can select which handling system is the ideal solution for your application based on the following characteristics.

### YOUR APPLICATION

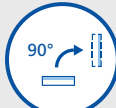
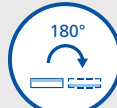
	Max. lift capacity 300 kg		2,000 kg		
Workpiece	Mainly porous and permeable e.g. cardboard boxes, bags and wooden boards		Mainly smooth and airtight e.g. metal plates and glass sheets		
Workpiece format	Max. 4,000 mm x 2,000 mm		Max. 8,000 mm x 2,000 mm		
Type of handling	Horizontal  MAX. 300 KG	90° swiveling  MAX. 120 KG	Horizontal  MAX. 2000 KG	90° swiveling  MAX. 1000 KG	180° turning  MAX. 500 KG
Lifting cycles per hour	up to ~ 500 picks/h		up to ~ 100 picks/h		



### PRODUCT RECOMMENDATION

	Vacuum tube lifter Jumbo	Vacuum lifting device VacuMaster
Application	Move goods weighing up to 300 kg quickly and frequently	Move heavy loads weighing up to 2,000 kg ergonomically and securely
Functions	Vacuum-generated holding force and lifting force	Vacuum-generated holding force, lifting force generated by chain hoist
Product information	Page 12	Page 24

Your Schmalz system consultant would be happy to help you select the right system to fit your requirements. Contact us and benefit from our expertise and years of experience in the field of vacuum handling technology:  
[WWW.SCHMALZ.COM/SALESNETWORK](http://WWW.SCHMALZ.COM/SALESNETWORK)

## Design and Function

### VACUUM TUBE LIFTER JUMBO

The vacuum tube lifter Jumbo consists of a vacuum generator, a lifting unit, an operating unit and vacuum gripper. The Jumbo only uses vacuum to raise and lower loads.

#### Picking up and Lifting the Load

- The vacuum generator (pump, blower or ejector) generates a vacuum in the system by continually evacuating air.
- The difference between the negative pressure and the ambient pressure draws the workpiece to the vacuum gripper. This is generally called "picking up" the workpiece.
- Once the workpiece has been picked up, the flow rate causes the lift tube to contract. The workpiece is then lifted.

#### Lowering and Releasing the Load

- Operating the control element feeds atmospheric air into the system ("venting"). The vacuum is reduced.
- This causes the lift tube to expand and the load is lowered. The lifting height can be precisely controlled by controlling the amount of atmospheric air that is fed into the system. To release the load, the vacuum is completely eliminated through maximum venting via the operator handle.

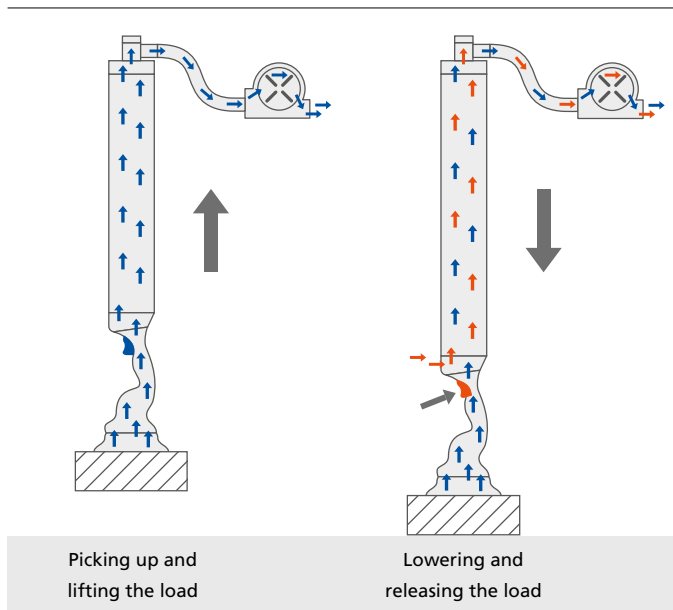

### VACUUM LIFTING DEVICE VACUMASTER

The vacuum lifting device VacuMaster consists of a vacuum generator, load beam with vacuum reservoir and vacuum distributor, an operator handle and suction plates. The vacuum holds the workpiece and a chain hoist is used to lift the workpiece.

#### Picking up and Lifting the Load

- The vacuum generator (pump or ejector) generates a vacuum first in the vacuum reservoir and then in the vacuum distributor by evacuating the air.
- The difference between the negative pressure and the ambient pressure draws the workpiece to the suction plates when the device is placed onto the workpiece. This is generally called "picking up" the workpiece.

#### Lowering and Releasing the Load

- The lifting device with the load that has been picked up is moved up and down by controlling the chain hoist.
- To release the load, the vacuum in the distributor is eliminated through atmospheric venting (activating the valve). The vacuum reservoir remains filled for the next lifting process.

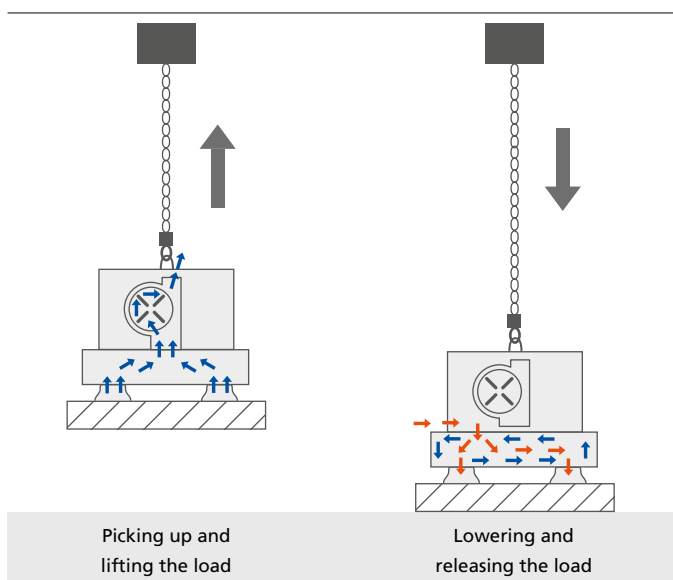

# Design

## Important Information for Designing Your System

When designing the perfect handling solution, there are a large number of deciding factors at play. Using the following questions, you can prepare yourself for the design discussion with your Schmalz system consultant.

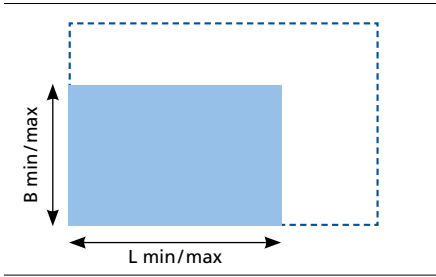

### 1. WORKPIECE

**What are the dimensions of your workpiece [mm]?**

Minimum \_\_\_\_\_

Maximum \_\_\_\_\_

**How thick is the workpiece [mm]?**

Minimum \_\_\_\_\_

Maximum \_\_\_\_\_

**How much does the workpiece weigh [kg]?**

Minimum \_\_\_\_\_

Maximum \_\_\_\_\_

**What is the workpiece material and what are the properties of this material (surface, porosity, etc.)?**

Material \_\_\_\_\_

Airtight

Smooth

Porous

Rough/textured

**Are there sample workpieces available at the location?**

Yes

No

With no airtight workpieces we recommend the implementation of lifting tests.

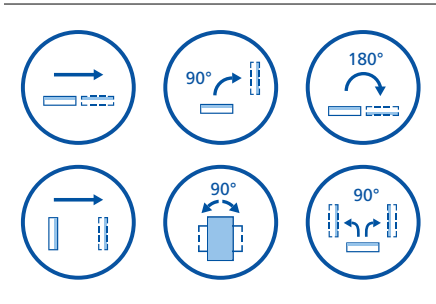

### 2. HANDLING TASK

**What is the workpiece's starting position?**

Horizontal

Vertical

**How will the workpiece be handled?**

Placed horizontally

Swiveled by 90°

Placed vertically

Rotated by 90°

Turned by 180°

**What are the minimum and maximum stack heights [mm]?**

Consider e.g. building columns in production areas, roof girders or cable bridges

Minimum \_\_\_\_\_

Maximum \_\_\_\_\_

**How frequently must workpieces be lifted?**

Picks per hour \_\_\_\_\_



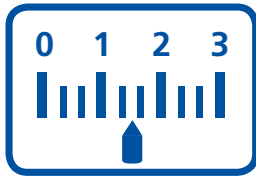

### 3. POWER SUPPLY

**What kind of power supply is available?**

Line voltage (V/Hz) \_\_\_\_\_

Compressed air (bar) \_\_\_\_\_

Standard line voltage for devices with a vacuum blower or vacuum pump:  
400 V 50 Hz (other voltage or frequency ranges available on request). Optimal  
input pressure (flow pressure) for devices with a vacuum ejector: 5.5 to 6 bar.

---

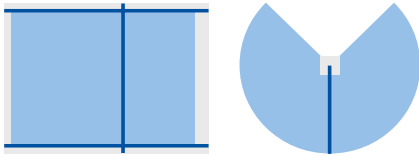

### 4. WORKING AREA

**How large is the working area that needs to be covered [mm]?**

LxB \_\_\_\_\_ or radius \_\_\_\_\_

**How high are the ceilings [mm]?**

\_\_\_\_\_

**What obstacles need to be taken into account?**

e.g. building columns in production areas, roof girders, pipes, light fixtures or  
cable bridges

---

**Which crane system or which kind of mounting might be used?**

Crane system

Jib crane

Ceiling mounting

Floor mounting (column)

Portal mounting

Wall mounting

Required concrete quality for anchoring a crane: at least B25 or C25/235

Required concrete thickness: at least 200 mm for edge distance at least 100 mm

Required concrete thickness: at least 130 mm for edge distance at least 200 mm

---

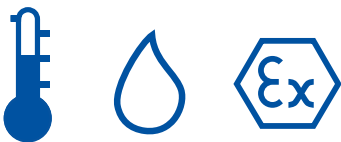

### 5. ADDITIONAL REQUIREMENTS

**What are the additional environmental requirements?**

Special environmental requirements necessitate special product solutions,  
for example:

Extreme temperatures (heat, deep freeze sector)

Particularly high humidity

Clean room conditions

Heavy contamination

Avoidance of marks

Explosion protection zone

Additional:

\_\_\_\_\_  
\_\_\_\_\_  
\_\_\_\_\_

# Service

## Individually Tailored Service

At Schmalz, we strive to be your single go to source for all your vacuum lifting needs from start to finish. That's why, alongside optimized product solutions, we also offer you a comprehensive range of services. Our system consultants offer quality advice regarding all your vacuum system needs, from planning and design to installation and start of operation, and much more.



### On-Site Consultation

We support you every step of the way when designing a solution for your handling tasks. Our system consultants in the field are happy to advise you on-site. We would also be happy to provide you with a demonstration of our products at your location.



### Test Center

Every workpiece is different. In order to err on the side of caution when designing systems, we also perform lifting tests with your sample workpieces upon request.



### Assembly and Start of Operations

Our experienced service technicians can perform the entire installation upon request, including setup of the electrical connection by a qualified electrical specialist.



### Safety Inspection

Before the initial start of operations, we recommend performing a safety inspection in accordance with standard accident prevention regulations. We would be happy to advise you on this topic.



### Operation

We would be glad to provide training for you and your employees on location so that you can operate your handling system optimally. During ongoing operation, we promise to quickly and reliably provide you with replacement and wearing parts.



### Warranty

When you choose Schmalz products, you're putting your trust in quality that's "Made in Germany". We offer a warranty for our handling systems. If necessary, our service personnel can be on-location quickly anywhere in the world to provide efficient, straightforward assistance.

# Contact

## Own Subsidiaries and Trade Partners in More Than 80 Countries

Our sales network of local field representatives, international subsidiaries and trade partners ensures quick and competent information and advice.

### CANADA

Schmalz Vacuum Technology Ltd.

14-2900 Argentia Road

ON L5N 7X9 Mississauga

Ontario

T: +1 905 569 9520

F: +1 905 569 8256

[schmalz@schmalz.ca](mailto:schmalz@schmalz.ca)

### INDIA

Schmalz India Pvt. Ltd.

EL – 38 'J' Block MIDC

Bhosari

411026 Pune

T: +91 20 4072 5500

F: +91 20 4072 5588

[schmalz@schmalz.co.in](mailto:schmalz@schmalz.co.in)

### UNITED STATES

Schmalz Inc.

5850 Oak Forest Drive

Raleigh, NC 27616

T: +1 919 713 0880

F: +1 919 713 0883

[schmalz@schmalz.us](mailto:schmalz@schmalz.us)

### WORLDWIDE

#### Headquarters in Germany

J. Schmalz GmbH

Johannes-Schmalz-Str.1

72293 Glatten

T: +49 7443 2403-0

F: +49 7443 2403-259

[schmalz@schmalz.de](mailto:schmalz@schmalz.de)

You can find contact information for our trade partners in 80 countries at [WWW.SCHMALZ.COM/SALESNETWORK](http://WWW.SCHMALZ.COM/SALESNETWORK)

# Workshop Equipment

## Damage-Free Storage, Transport and Clamping of Workpieces



Schmalz workshop equipment serves as an important aid in industry and professional trades. Transport trolleys facilitate space-saving storage of workpieces between individual production steps. Specifically, these trolleys are used to transport painted furniture pieces, sheets, profiles, metal/plastic components and solar panels, among other things.

Vacuum workbenches and vacuum work stands round off the product range. The vacuum is switched on and off using a foot-operated switch; workpieces are clamped using suction plates and fastened in place for processing. The workbenches and work stands can be adjusted to any height to enable ergonomic working.

## At your side worldwide

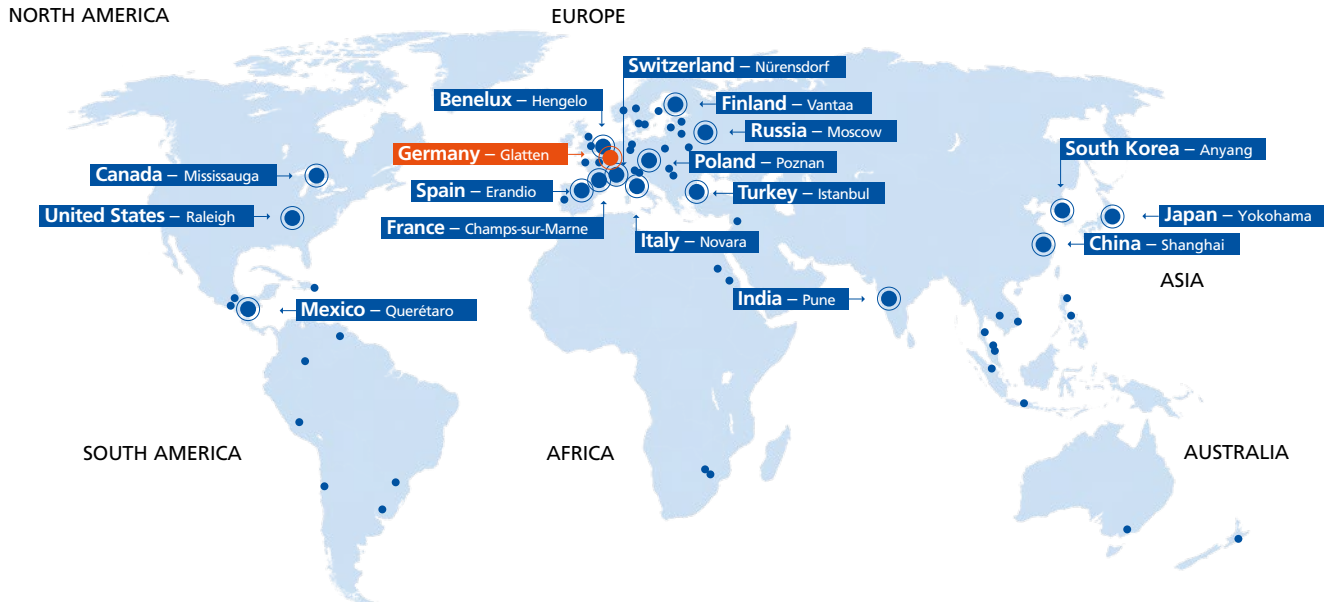

### Subsidiaries

Schmalz Benelux – Hengelo (NL)  
 Schmalz Canada – Mississauga  
 Schmalz China – Shanghai  
 Schmalz Finland – Vantaa  
 Schmalz France – Champs-sur-Marne  
 Schmalz India – Pune  
 Schmalz Italy – Novara  
 Schmalz Japan – Yokohama

Schmalz Mexico – Querétaro  
 Schmalz Poland – Suchy Las (Poznan)  
 Schmalz Russia – Moscow  
 Schmalz South Korea – Anyang  
 Schmalz Spain – Erandio (Vizcaya)  
 Schmalz Switzerland – Nürens Dorf  
 Schmalz Turkey – Istanbul  
 Schmalz United States – Raleigh (NC)

### Headquarters

Schmalz Germany – Glatten

### Sales Partners

You can find the Schmalz sales partner in your country at: [WWW.SCHMALZ.COM/SALESNETWORK](http://WWW.SCHMALZ.COM/SALESNETWORK)

## Vacuum Automation

T: +49 7443 2403-102

## Handling Systems

T: +49 7443 2403-108

### J. Schmalz GmbH

Johannes-Schmalz-Str. 1  
 72293 Glatten, Germany  
 T: +49 7443 2403-0  
 schmalz@schmalz.de  
 WWW.SCHMALZ.COM