

FABCO-AIR

H-Series Air Cylinders

HUMPHREY INTERCHANGE



FABCO-AIR

air cylinders

outstanding design and construction...
superior performance and reliability

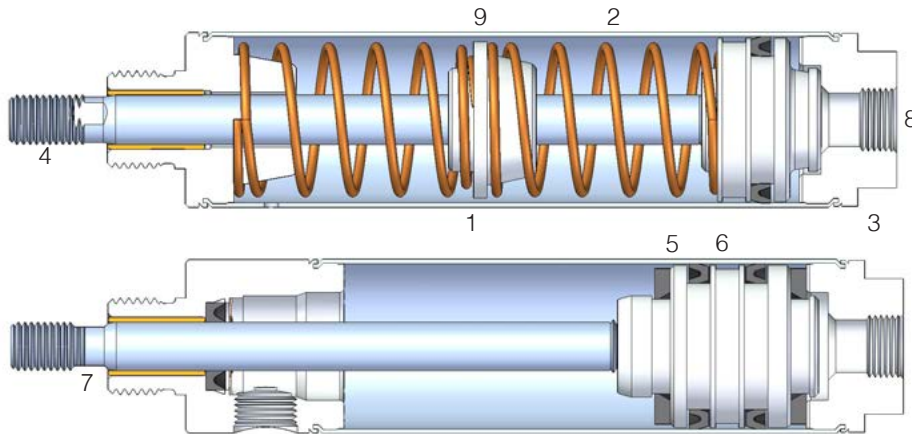

1. **Barrel** – Stainless steel (Type 304). Drawn and polished I.D. provides ideal lube-holding, low friction surface. Matte finish on O.D. Barrel attached to heads by Fabco roll-forming process.

2. **Return Springs** – High tensile strength music wire. Shotpeened...to relieve stresses for longer life.

3. **Heads** – Aluminum. Internal face grooved for positive air flow to piston seals.

4. **Piston Rod** - 303 Stainless Steel standard all models. Wrench flats, standard on most models, and chamfered for easy wrench contact without rod damage. Threads are roll formed for strength and durability.

5. **Piston** - Unique Fabco Piston may be factory assembled in two different ways – same overall dimensions with or without bumpers. Piston threads are Roll Formed for strength and durability.

6. **Seals** – Buna N standard on all models. Fluorocarbon (Viton...Option F) available for high ambient temperatures, for extremely high cycling conditions with limited lubrication or mild chemical resistance (air supply contaminants and/or lubricants). Seal design ensures constant contact with cylinder barrel eliminating seal collapse and blowby.

7. **Rod Bushing** – Oil permeated bronze. Ball-sized to close tolerance... provides rod support and smooth, low friction rod movement for longer cylinder life.

8. **Pressure Ports** – Full, unrestricted porting for maximum air flow...combines with groove in heads to provide fast cylinder response and smooth rod movement.

9. **Spacers** – Spacers ensure a uniform spring rate and prohibit collapse of springs, providing maximum life.

10. **Accessories** – (see page 18 & 19) Steel mounting nuts, mounting brackets, rod clevises, etc., are burnished and bright zinc plated.

FABCO-AIR cylinder selection guide

Air cylinders have an excellent ability to provide fast response and rapid movement from the energy of compressed air. Rapid indexing, stamping, punching, part location,

etc., are ideally suited to air cylinders. Applications requiring extremely slow and smooth, or precise movement are more difficult to satisfy due to the compressibility of air. Consult Factory.

mounting

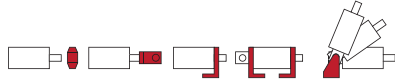

Mount to centerline of work to avoid side load on rod. Mount securely, without over-torquing mounting nuts. Check frequently for loose mountings. A secure mount, accurately placed, promotes cylinder performance and endurance. Side load on rod should be eliminated. Severe side load or stress can cause rod breakage, excessive bushing wear, and scoring of piston/barrel. Consider Option N (Wearstrip).

Reduce adverse effect of side load by attaching a universal rod eye to the piston rod. Also, consider utilizing only part of total stroke...keep piston "back" in barrel for greater column strength.

Avoid "bottoming-out" piston on cylinder heads at high pressures. Consider Option B (Bumper).

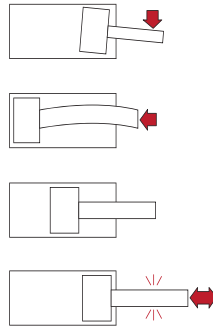

lubrication

All models are factory prelubricated for optimum life and performance. Periodically lubricate internally with a non-detergent mineral-base oil. Automatic air line lubricators are most commonly used. To solve lubrication problems due to lubricant backflow during control valve exhaust cycle, install a Fabco quick exhaust valve directly to the cylinder port. This stops backflow and allows progressive flow of oil to cylinder. Avoid using higher pressure than is actually required. Nominal air pressure provides optimum cylinder life, reduces use and cost of compressed air, and saves energy.

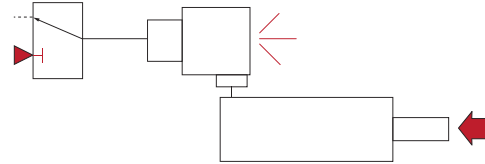

air cylinder application factors

single acting types

spring return

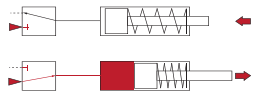

spring extend

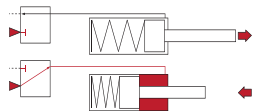

- Spring return (single acting): Air pressure produces force in one pushing direction only, causing rod to extend.
- Spring extend (single acting reverse): Air pressure produces force in one pulling direction only, causing rod to retract.
- Spring returns rod to normal position in one quick motion, determined by control valve's flow capacity and cylinder volume. Flow control (metering) of exhausting air during return stroke does not provide optimum smoothness of movement (consider Double Acting models for smoothest movement).
- Only one 3-way valve is required...less expensive than valving for double acting cylinders.
- Consider when compressed air supply is limited or must be conserved.
- Mount to insure that vent in side of barrel can breathe freely.

double acting types

double acting

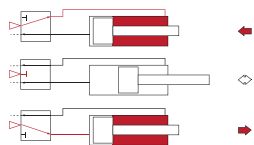

double-end rod

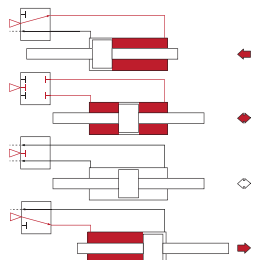

- Air pressure produces force in either pushing or pulling direction. Pushing force is greater than pulling force due to smaller effective piston area on rod side of piston.
- Flow control (metering) of exhausting air can be performed in either direction. Air exhausts from the cylinders port opposite the port being pressurized. For smoothest movement, meter the exhausting air. Metering of the incoming pressure may produce erratic, jumpy cylinder action.
- Closed system. No vent (breather hole) to consider; see Single Acting above. Consider, when cylinder must operate in dirty ambient conditions.
- Air pressure produces equal force in both pushing and pulling directions due to equal piston area. Pressurizing both sides locks cylinder position in any given point.
- Fixed mounting of both rod ends allows movement of barrel only... barrel moves back and forth and rods are stationary. Caution: Do not side load rod (barrel weight, alignment, etc.).
- One rod can be used to perform a work function while second rod:
 - Permits operation of limit switches away from work function.
 - Permits attachment of guiding methods to eliminate rod rotation (alternate to hex rod)
 - Provides additional support to guard against rod deflection.

FABCO-AIR air cylinders

specifications



FORCE (F) is determined by square inches of piston area (A), and pressure (P) in PSIG. $F=A \times P$

VOLUME (V) in cubic inches is determined by square inches of piston area (A), and length of stroke (L). $V=A \times L$.

SPEED is affected by many variables (including force to move load, cylinder volume, control valve flow capacity, length of supply lines, etc.) making precise calculations difficult.

For Compressed Air to 200 PSIG

Ambient Temperature: -40°F to 160°F ...as standard

Ambient Temperature: -20°F to 400°F with Fluoroelastomer seals



Model Code	Bore Size I.D.	Port Size	Rod Diameter or (HEX)	Piston Area (in ²) Cylinder Volume (in ³ /inch of stroke)		Spring Force in Pounds if Cyl. is:	
				a	b (less rod)	c (normal)	c (actuated)
8	1/2	10-32 UNF	.187 (.187)	.20	.17	1	2
7	3/4	1/8 PIPE	.250 (.250)	.44	.39	1 1/2	5
6	1 1/16	1/8 PIPE	.312 (.375)	.89	.81	4	8
25	1 1/4	1/8 PIPE	.437 (N.A.)	1.23	1.08	7	14
5	1 1/2	1/8 PIPE	.437 (.437)	1.77	1.62	6	12
75	1 3/4	1/4 PIPE	.500 (N.A.)	2.41	2.21	12	24
4	2	1/4 PIPE	.625 (N.A.)	3.14	2.84	15	30
3	2 1/2	1/4 PIPE	.625 (N.A.)	4.91	4.60	N/A	N/A

how to order

model code - type - stroke length options
 A B C D

examples:

6-S-2
 5-DP-4M
 8-D-2-1/2B

type		model codes / bore sizes available								recommended maximum stroke in.	comments
		8	7	6	25	5	75	4	3		
D	double acting nose mount	●	●	●	●	●	●	●	●	12	<ul style="list-style-type: none"> Standard strokes are in 1" increments (1/2" for model code 8). Fractional strokes also available. Consult factory. Stroke tolerance is 1/32". Longer than standard stroke lengths are available. Consult factory. When specifying longer than standard stroke lengths, consider possible rod deflection, adequate lubrication, high speed friction, etc. No warranty.
DP	double acting pivot/double end mount	●	●	●	●	●	●	●	●	12	
D2EY	double acting double end rod	●	●	●	●	●	●	●	●	12	
BFD	double acting block front mount	●	●	●		●				12	
S	single acting nose mount	●	●	●	●	●	●	●		6	
SP	single acting pivot mount	●	●	●	●	●	●	●		6	
SH	single acting nose mount/HEX rod	●	●	●		●				6	
SHP	single acting pivot mount/HEX rod	●	●	●		●				6	
SR	single acting reverse/nose mount	●	●	●	●	●	●	●		4	
SRP	single acting reverse/pivot mount	●	●	●	●	●	●	●		4	
BFS	single acting block front mount	●	●	●		●				6	
BFSR	single acting reverse/block front mount	●	●	●		●				4	

FABCO-AIR air cylinders

how to order options

D

type	description	page	options available												
			A	B	F	J	K	L	M	N	P	R	T	W	U
D	double acting nose mount	6	●	●	●				●	●	●			●	
DP	double acting pivot/double-end mount	7		●	●	●	●	●	●	●	●	●	●	●	●
D2EY	double acting double-end rod	8			●	●	●	●			●	●		●	
BFD	double acting block front mount	9		●	●				●	●	●			●	
S	single acting nose mount	10	●		●					●				●	
SP	single acting pivot mount	11			●					●		●	●	●	●
SH	single acting nose mount/HEX rod	12	●		●					●				●	
SHP	single acting pivot mount/HEX rod	13			●					●		●	●	●	●
SR	single acting reverse/nose mount	14			●					●	●			●	●
SRP	single acting reverse/pivot mount	15			●					●	●	●	●	●	●
BFS	single acting block front mount	16			●					●				●	
BFSR	single acting reverse/block front mount	17			●					●	●			●	

example: 7-D-4BN (3/4 Bore/Double acting cylinder with bumpers and wearstrip)

option	option decription
A	SIDE PORTED REAR HEAD - Locates rear port on side of body. Available on type D, S and SH (See product pages for details).
B	BUMPER - Reduce mechanical noise - Absorb shock - Negligible stroke change due to compression set - Buna N standard. (Viton Bumpers standard when option B is ordered with Option F.) - Single Acting Models - one bumper opposite spring side on piston - Double Acting Models - one bumper on both sides of piston - Standard on type D2EY.
F	FLUOROELASTOMER SEALS (VITON) - For ambient temperatures of -20° to 400° F.
J	ROTATE FRONT HEAD 90 - Front head is rotated 90° clockwise from rear port, viewed from rod end.
K	ROTATE FRONT HEAD 180 - Front head is rotated 180° clockwise from rear port, viewed from rod end.
L	ROTATE FRONT HEAD 270 - Front head is rotated 270° clockwise from rear port, viewed from rod end.
M	INTERNAL MAGNET - For use with Fabco Sensor Switches (see page 22 & 23).
N	WEARSTRIP - Protects pistons and barrel from wear due to minor rod deflection - Standard on type D, DP, and BFD with 5 inches or more of stroke. Standard on type SR and SRP with 3 inches or more of stroke. Not available on Model 8.
P	POLYPAK ROD SEALS - Provides excellent rod sealing capabilities at low pressures.
R	ROTATED REAR PIVOT TANG - Rotation of rear pivot tang 90°. Port remains in original position.
T	PIVOT PIN IN REAR TANG - Pivot pin pressed into rear tang. No bracket available. Not available in Models 3 and 4.
W	ROD WIPER - Provides a wiping action to remove most foreign material from exposed rod while maintaining adequate lubricating film. Protects rod and primary rod seal. Not available on Model 8.
U	REAR PIVOT BUSHING - Bushing in rear pivot hole. Hole diameter remains the same. Available on SP, SHP, SRP, DP of models 7, 6, 25, & 5. Standard on model 3 and 4. Note: Model 5 cylinders have no threads on tang (tang diameter is 1.0 inch).

FABCO-AIR air cylinders

D-type double acting / nose mount

- Stainless steel rod, standard.
- Simple, reliable design.
- Requires air pressure to extend and retract rod.
- Extend force exceeds retract force (smaller effective area on rod side of piston).
- Exclusive Fabco reversible piston.
- Specify option M (internal magnet) to operate sensors.
- Wearstrip standard: 5 inches or more of stroke (optional on shorter strokes. N/A on model 8).
- Options: A, B, F, M, N, P and W.
- Mounting nut included, except model 4 & 3 (order separately).
- Available accessories foot mount and rod clevis. See pages 18 & 19.

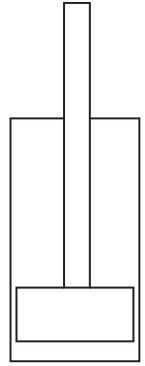

For product configuration utility, 3D CAD viewer, and 3D CAD Model downloads, Visit www.fabco-air.com.

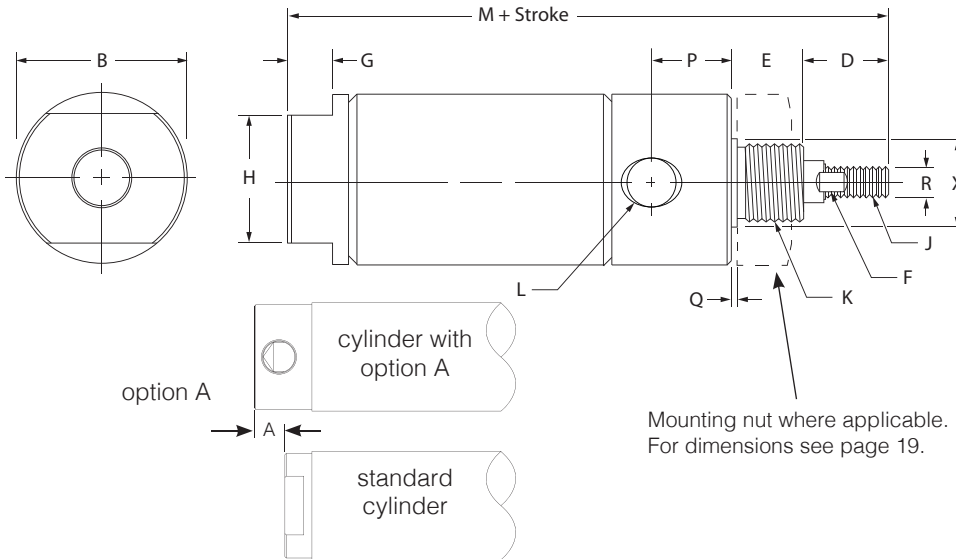

Media.....Compressed Air
 Pressure Range.....0-200 PSIG
 Temperature Range.....-40°F to 160°F Ambient*
 w/Fluoroelastomer.....-20°F to 400°F Ambient*
 Recommended maximum stroke.....12"
 *additional heat may be generated by seal friction (high speed cycling).

model code.	piston area* - in ²	
	volume - in ³ (per inch of stroke)	rod side
8	.20	.17
7	.44	.39
6	.89	.81
25	1.23	1.08
5	1.77	1.62
75	2.41	2.21
4	3.14	2.84
3	4.91	4.60

*Area x PSIG = Approximate Force

model & type (stroke)	bore	A add to dim. M	B dia.	D rod retracted	E nose length	F wrench flat	G flat	H flat	J rod thread x length	K nose thread	L port (NPSF)	M length	P	Q pilot	R rod dia.	X pilot -.001 -.006
8-D_-	1/2	.19	.62	.50	.41	none	.12	.37	10-32 x .50	7/16-20	10-32 UNF	2.62*	.37	.04	.187	.437
7-D_-	3/4	.44	.88	.50	.50	none	.16	.62	1/4-28 x .50	5/8-18	1/8	3.47	.48	.07	.250	.625
6-D_-	1 1/16	.25	1.12	.62	.50	.25	.25	.87	5/16-24 x .50	5/8-18	1/8	3.75	.52	.07	.312	.625
25-D_-	1 1/4	.31	1.31	1.00	.62	.38	.18	.87	7/16-20 x .75	3/4-16	1/8	4.75	.63	.07	.437	.750
5-D_-	1 1/2	.19	1.55	1.00	.62	.38	.25	.87	7/16-20 x .75	3/4-16	1/8	4.44	.62	.07	.437	.750
75-D_-	1 3/4	.56	1.81	1.19	.75	.44	.25	1.25	1/2-20 x .88	1-14	1/4	5.57	.72	.09	.500	1.030
4-D_-	2	.37	2.07	1.25	.81	.50	.31	1.25	1/2-20 x .88	1 1/4-12	1/4	5.56	.69	.12	.625	1.375
3-D_-	2 1/2	.37	2.62	1.25	.81	.50	.31	1.75	1/2-20 x .88	1 3/8-12	1/4	5.56	.69	.12	.625	1.500

* model 8 only - add 0.399 for Option M.

FABCO-AIR air cylinders

DP-type double acting / pivot mount or double-end mount

- Stainless steel rod, standard.
- Simple, reliable design.
- Requires air pressure to extend and retract rod.
- Extend force exceeds retract force (smaller effective area on rod side of piston).
- Exclusive Fabco reversible piston.
- Specify option M (internal magnet) to operate sensors.
- Wearstrip standard: 5 inches or more of stroke (optional on shorter strokes. N/A on model 8).
- Options: B, F, J, K, L, M, N, P, R, T, W and U.
- Versatile mounting, pivot, nose, double-end.
- Available accessories, pivot bracket, mounting nut, foot mount and rod clevis, see pages 18 & 19.

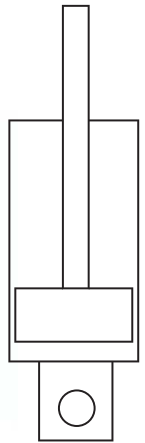

For product configuration utility, 3D CAD viewer, and 3D CAD Model downloads, Visit www.fabco-air.com.

Media.....Compressed Air
 Pressure Range.....0-200 PSIG
 Temperature Range.....-40°F to 160°F Ambient*
 w/Fluoroelastomer.....-20°F to 400°F Ambient*
 Recommended maximum stroke.....12"
 *additional heat may be generated by seal friction (high speed cycling).

model code.	piston area* - in ²	
	plain side	rod side
8	.20	.17
7	.44	.39
6	.89	.81
25	1.23	1.08
5	1.77	1.62
75	2.41	2.21
4	3.14	2.84
3	4.91	4.60

*Area x PSIG = Approximate Force

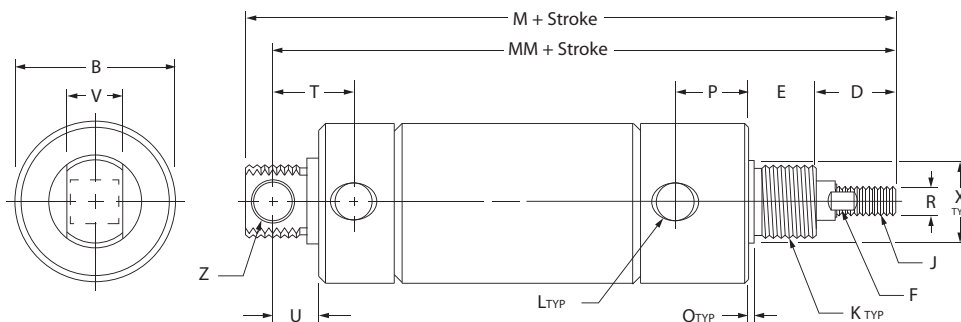

model & type (stroke)	bore	B dia.	D rod exten.	E nose length	F wrench flat	J rod thread x length	K nose & pivot thread	L port (NPSF)	M length	MM length	P	Q pilot	R rod dia.	T	U	V	X Pil. Dia. -.001 -.006	Z Pivot Hole Dia.
8-DP-	1/2	.62	.50	.41	none	10-32 x .50	7/16-20	10-32 UNF	3.31*	3.06*	.37	.04	.187	.42	.25	.31	.437	.16
7-DP-	3/4	.88	.50	.50	none	1/4-28 x .50	5/8-18	1/8	4.54	4.25	.48	.07	.250	.66	.34	.38	.625	.25
6-DP-	1 1/16	1.12	.62	.50	.25	5/16-24 x .50	5/8-18	1/8	4.62	4.34	.52	.07	.312	.62	.34	.38	.625	.25
25-DP-	1 1/4	1.31	1.00	.62	.38	7/16-20 x .75	3/4-16	1/8	5.83	5.47	.63	.07	.437	.91	.41	.50	.750	.25
5-DP-	1 1/2	1.55	1.00	.62	.38	7/16-20 x .75	3/4-16	1/8	5.50	5.12	.62	.07	.437	.81	.50	.62	.750	.38
75-DP-	1 3/4	1.81	1.19	.75	.44	1/2-20 x .88	1-14	1/4	7.13	6.63	.72	.09	.500	.98	.50	.62	1.030	.38
4-DP-	2	2.07	1.25	.81	.50	1/2-20 x .88	1 1/4-12	1/4	6.93	6.50	.69	.12	.625	1.0	.57	.75	1.375	.38
3-DP-	2 1/2	2.62	1.25	.81	.50	1/2-20 x .88	1 3/8-12	1/4	6.93	6.50	.69	.12	.625	1.0	.57	.75	1.500	.38

* model 8 only - add 0.399 for Option M.

FABCO-AIR air cylinders

D2EY-type double acting - double end rod / double end mount

- Air pressure produces equal force in both directions due to equal piston area; permits locking in mid stroke.
- One rod can be used to perform work function, second rod to operate limit switches, provide support or guide.
- Fixed mounting of both rod ends allows movement of barrel only.
- Bumpers and Stainless steel rod, standard.
- Options: F,J,K,L,N,P,W.
- Two mounting nuts included, except Model 3 & 4 (order separately).
- Available accessories foot mount, mounting nut and rod clevis, see pages 18 & 19.

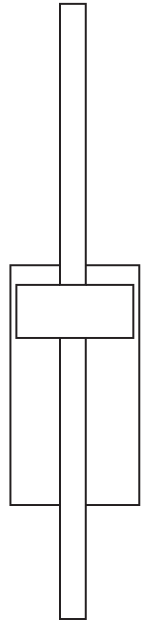

For product configuration utility, 3D CAD viewer, and 3D CAD Model downloads, Visit www.fabco-air.com.

Media.....Compressed Air
 Pressure Range.....0-200 PSIG
 Temperature Range.....-40°F to 160°F Ambient*
 w/Fluoroelastomer.....-20°F to 400°F Ambient*
 Recommended maximum stroke.....12"
 *additional heat may be generated by seal friction (high speed cycling).

model code.	piston area* - in ²
	volume - in ³ (per inch of stroke)
8	.17
7	.39
6	.81
25	1.08
5	1.62
75	2.21
4	2.84
3	4.6

*Area x PSIG = Approximate Force

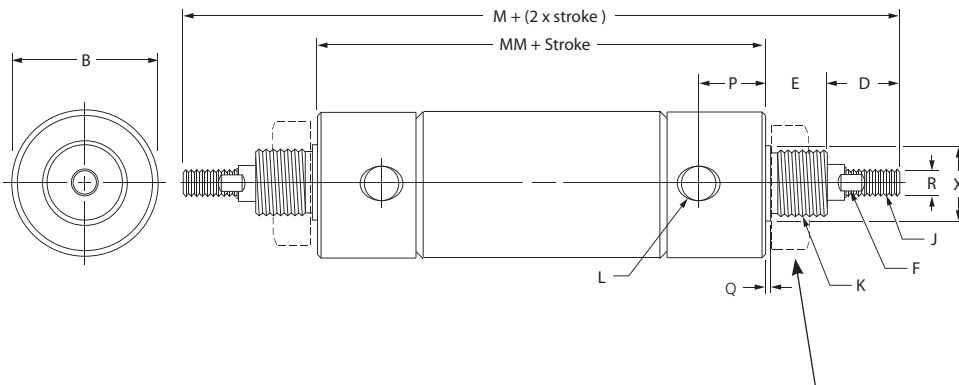

Mounting nut where applicable.
 For dimensions see page 19.

model & type (stroke)	bore	B dia.	D rod retracted	E nose length	F wrench flat	J rod thread x length	K nose thread	L port (NPSF)	M length	MM length	P	Q pilot rod dia.	R rod dia.	X pilot -001 -006
8-D2EY-	1/2	.62	.50	.41	none	10-32 x .50	7/16-20	10-32 UNF	3.88	2.07	.37	.04	.187	.437
7-D2EY-	3/4	.88	.50	.50	none	1/4-28 x .50	5/8-18	1/8	5.03	3.03	.48	.07	.250	.625
6-D2EY-	1 1/16	1.12	.62	.50	.25	5/16-24 x .50	5/8-18	1/8	5.32	3.07	.52	.07	.312	.625
25-D2EY-	1 1/4	1.31	1.00	.62	.38	7/16-20 x .75	3/4-16	1/8	6.83	3.58	.63	.07	.437	.750
5-D2EY-	1 1/2	1.55	1.00	.62	.38	7/16-20 x .75	3/4-16	1/8	6.63	3.39	.62	.07	.437	.750
75-D2EY-	1 3/4	1.81	1.19	.75	.44	1/2-20 x .88	1-14	1/4	8.57	4.69	.72	.09	.500	1.030
4-D2EY-	2	2.07	1.25	.81	.50	1/2-20 x .88	1 1/4-12	1/4	8.31	4.19	.69	.12	.625	1.375
3-D2EY-	2 1/2	2.62	1.25	.81	.50	1/2-20 x .88	1 3/8-12	1/4	8.31	4.19	.69	.12	.625	1.500

FABCO-AIR air cylinders

BFD-type

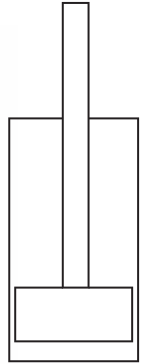

- Versatile mounting... through-head, front mount using pilot.
- Stainless steel rod, standard.
- Simple, reliable design.
- Requires air pressure to extend and retract rod.
- Extend force exceeds retract force (smaller effective area on rod side of piston).
- Exclusive Fabco reversible piston.
- Specify option M (internal magnet) to operate sensors.
- Wearstrip standard (double acting only): 5 inches or more of stroke (optional, shorter strokes).
- Options: B, F, M, N, P.
- Available accessories, rod clevis, see pages 18 & 19.

For product configuration utility, 3D CAD viewer, and 3D CAD Model downloads, Visit www.fabco-air.com.

Media.....Compressed Air
 Pressure Range.....0-200 PSIG
 Temperature Range.....-40°F to 160°F Ambient*
 w/Fluoroelastomer.....-20°F to 400°F Ambient*
 Recommended maximum stroke.....12"
 *additional heat may be generated by seal friction (high speed cycling).

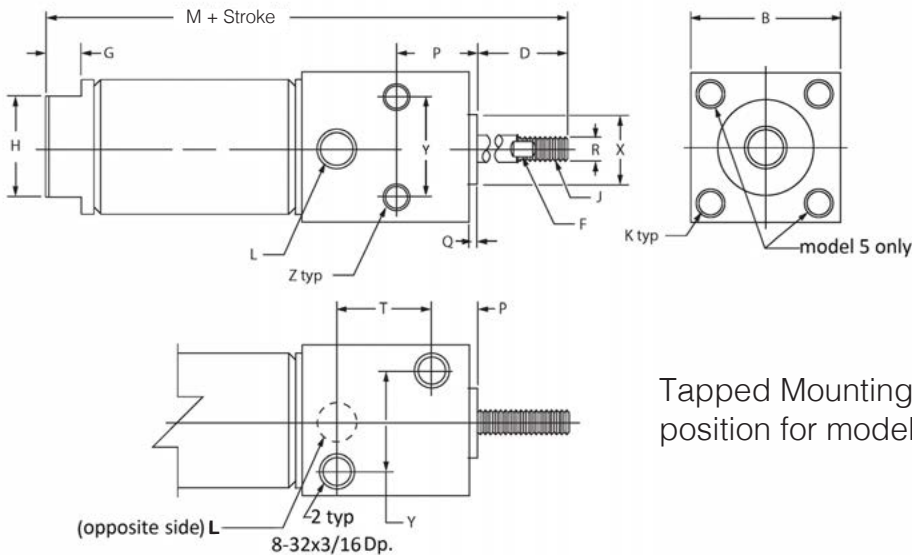

Tapped Mounting hole (Z)
 position for model 8-BFD only

model code.	piston area* - in ² volume - in ³ (per inch of stroke)	
	plain side	rod side
8-BFD	.20	.17
7-BFD	.44	.39
6-BFD	.89	.81
5-BFD	1.77	1.62

*Area x PSIG = Approximate Force

model & type (stroke)	bore	B Square.	D rod exten.	F Wrench flat	G flat	H flat	J rod thread x length	K mounting holes	L port (NPSF)	M length	P	Q pilot	R rod dia.	T	X pilot dia. -.001 -.006	Y	Z mounting holes
8-BFD- <u> </u>	1/2	.75	.50	none	.12	.37	10-32 x .50	Two #8-32 holes on .75 diameter bolt circle	10-32 UNF	2.62	.31	.06	.187	.44	.437	.44	Two #8-32 holes
7-BFD- <u> </u>	3/4	1.00	1.06	.22	.16	.62	1/4-28 x .75	Two #10-32 holes on 1.0 diameter bolt circle	1/8	4.03	.47	.09	.250	.51	.625	.62	Two holes drill and c' bored for 10-32 cap screw tap 1/4-20
6-BFD- <u> </u>	1 1/16	1.25	1.12	.25	.25	.87	5/16-24 x .75	Two #10-32 holes on 1.25 diameter bolt circle	1/8	4.75	.72	.09	.312	.54	.750	.81	Two holes drill and c' bored for 10-32 cap screw tap 1/4-20
5-BFD- <u> </u>	1 1/2	1.75	1.50	.38	.25	.87	7/16-20 x 1.25	Two #1/4-20 holes on 1.75 diameter bolt circle	1/4	5.44	1.00	.12	.437	.66	1.000	1.12	Two holes drill and c' bored for 1/4-20 cap screw tap 5/16-18

FABCO-AIR air cylinders

S-type single acting / nose mount

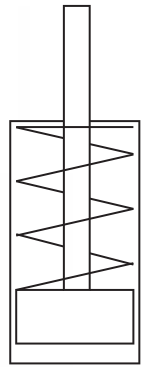

- Stainless steel rod, standard.
- Economical - requires air pressure only to extend rod.
- Stress relieved spring/s retract rod.
- Options: A, F and N.
- Mounting nut included, except model 4 (order separately).
- Available accessories: foot mount and rod clevis, see pages 18 & 19.

For product configuration utility, 3D CAD viewer, and 3D CAD Model downloads, Visit www.fabco-air.com.

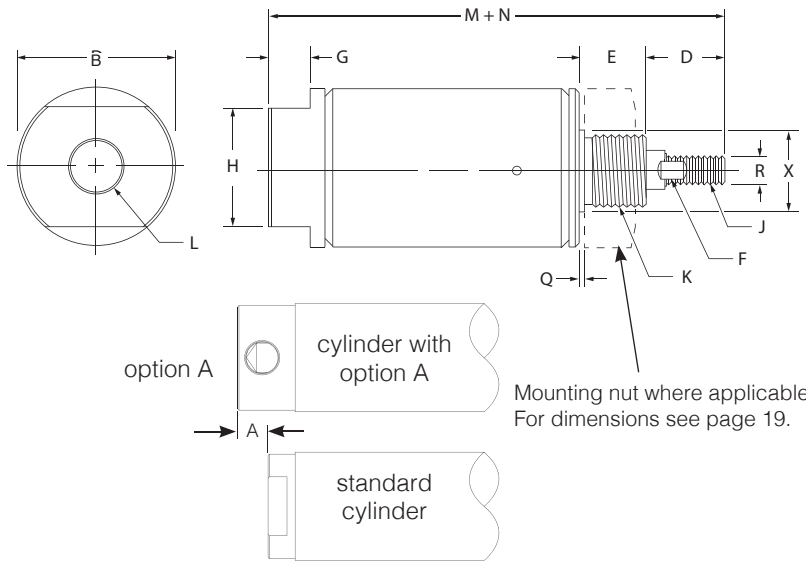

Media.....Compressed Air
 Pressure Range.....0-200 PSIG
 Temperature Range.....-40°F to 160°F Ambient*
 w/Fluoroelastomer.....-20°F to 400°F Ambient*
 Recommended maximum stroke......6"
 *additional heat may be generated by seal friction (high speed cycling).

model code.	piston area* - in ²		spring force pounds	
	volume - in ³ (per inch of stroke)		free	comp
8	.20		1	2
7	.44		1.5	5
6	.89		4	8
25	1.23		7	14
5	1.77		6	12
75	2.41		12	24
4	3.14		15	30

*Area x PSIG = Approximate Force

model & type (stroke)	bore	A add to dim. M	B dia.	D rod exten.	E nose length	F wrench flat	G flat	H flat	J rod thread x length	K nose thread	L port (NPSF)	M length	N		Q pilot	R rod dia.	X pilot dia. -.001 -.006
													for each stroke increment of:	add to M			
8-S-	1/2	.19	.56	.50	.31	none	.12	.37	10-32 x .50	3/8-24	10-32 UNF	1.81	1/2"	.94	.04	.187	.375
7-S-	3/4	.44	.81	.50	.44	none	.16	.62	1/4-28 x .50	1/2-20	1/8	2.00	1"	1.69	.07	.250	.500
6-S-	1 1/16	.25	1.12	.62	.50	.25	.25	.87	5/16-24 x .50	5/8-18	1/8	2.56	1"	1.56	.07	.312	.625
25-S-	1 1/4	.31	1.31	1.00	.62	.38	.18	.87	7/16-20 x .75	3/4-16	1/8	3.41	1"	1.81	.07	.437	.750
5-S-	1 1/2	.19	1.55	1.00	.62	.38	.25	.87	7/16-20 x .75	3/4-16	1/8	3.19	1"	1.69	.07	.437	.750
75-S-	1 3/4	.56	1.81	1.19	.75	.44	.25	1.25	1/2-20 x .88	1-14	1/4	3.85	1"	2.00	.09	.500	1.030
4-S-	2	.37	2.07	1.25	.81	.50	.31	1.25	1/2-20 x .88	1 1/4-12	1/4	4.17	1"	2.00	.12	.625	1.375

FABCO-AIR air cylinders

SP-type single acting / pivot mount or double-end mount

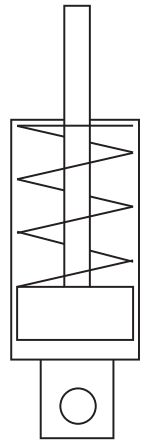

- Stainless steel rod, standard.
- Economical - requires air pressure only to extend rod.
- Stress relieved spring/s retract rod.
- Options: F, N, R, T and U.
- Versatile mounting, pivot, nose, double-end.
- Available accessories, pivot bracket, foot mount, mounting nut and rod clevis, see pages 18 & 19.

For product configuration utility, 3D CAD viewer, and 3D CAD Model downloads, Visit www.fabco-air.com.

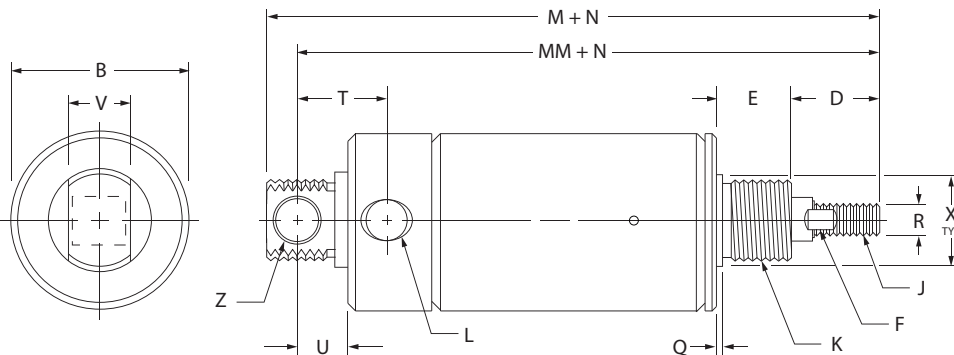

Media.....Compressed Air
 Pressure Range.....0-200 PSIG
 Temperature Range.....-40°F to 160°F Ambient*
 w/Fluoroelastomer.....-20°F to 400°F Ambient*
 Recommended maximum stroke.....6"
 *additional heat may be generated by seal friction (high speed cycling).

model code.	piston area* - in ²		spring force pounds	
	volume - in ³ (per inch of stroke)	free	comp	
8	.20	1	2	
7	.44	1.5	5	
6	.89	4	8	
25	1.23	7	14	
5	1.77	6	12	
75	2.41	12	24	
4	3.14	15	30	

*Area x PSIG = Approximate Force

model & type (stroke)	bore	B dia.	D rod exten.	E nose length	F wrench flat	J rod thread x length	K nose thread	L port (NPSF)	M length	MM length	N		Q pilot	R rod dia.	T	U	V	X Pil. Dia. -.001-.006 front (rear)	Z Pivot Hole Dia.
											for each stroke increment of.	add to M							
8-SP- ₋	1/2	.62	.50	.31	none	10-32 x .50	3/8-24 (7/16-20)	10-32 UNF	2.50	2.25	1/2"	.94	.04	.187	.42	.25	.31	.375 (.437)	.16
7-SP- ₋	3/4	.81	.50	.44	none	1/4-28 x .50	1/2-20 (5/8-18)	1/8	3.06	2.77	1"	1.69	.07	.250	.66	.34	.38	.500 (.625)	.25
6-SP- ₋	1 1/16	1.12	.62	.50	.25	5/16-24 x .50	5/8-18 TYP.	1/8	3.44	3.16	1"	1.56	.07	.312	.62	.34	.38	.625	.25
25-SP- ₋	1 1/4	1.31	1.00	.62	.38	7/16-20 x .75	3/4-16 TYP.	1/8	4.50	4.14	1"	1.81	.07	.437	.91	.41	.50	.750	.25
5-SP- ₋	1 1/2	1.55	1.00	.62	.38	7/16-20 x .75	3/4-16 TYP.	1/8	4.25	3.88	1"	1.69	.07	.437	.81	.50	.62	.750	.38
75-SP- ₋	1 3/4	1.81	1.19	.75	.44	1/2-20 x .88	1-14 TYP.	1/4	5.41	4.91	1"	2.00	.09	.500	.98	.50	.62	1.030	.38
4-SP- ₋	2	2.07	1.25	.81	.50	1/2-20 x .88	1 1/4-12 TYP.	1/4	5.54	5.11	1"	2.00	.12	.625	1.0	.57	.74	1.375	.381

FABCO-AIR air cylinders

SH-type single acting, non-rotating rod / nose mount

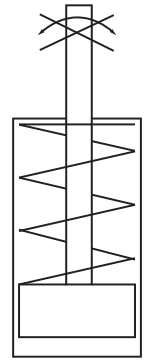

- Stainless steel rod, standard.
- Non-rotating hex rod-no special guides required.
- Requires air pressure only to extend rod.
- Stress relieved springs retract rod.
- Options: A, F and N.
- Mounting nut included.
- Available accessories: foot mount and rod clevis, see pages 18 & 19.

For product configuration utility, 3D CAD viewer, and 3D CAD Model downloads, Visit www.fabco-air.com.

Media.....Compressed Air
 Pressure Range.....0-200 PSIG
 Temperature Range.....-40°F to 160°F Ambient*
 w/Fluoroelastomer.....-20°F to 400°F Ambient*
 Recommended maximum stroke......6"
 *additional heat may be generated by seal friction (high speed cycling).

model code.	piston area* - in ²		spring force pounds	
	volume - in ³ (per inch of stroke)	free	comp	
8	.20	1	2	
7	.44	1.5	5	
6	.89	4	8	
5	1.77	6	12	

*Area x PSIG = Approximate Force

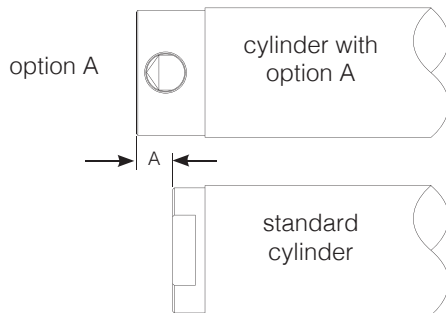
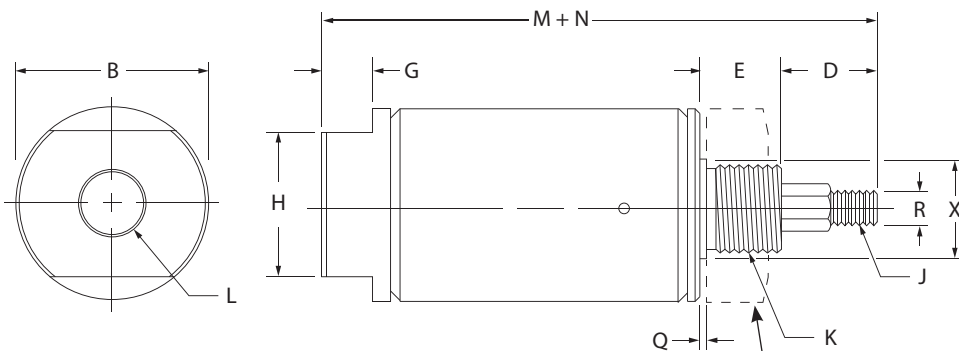

Mounting nut where applicable. For dimensions see page 19.

model & type (stroke)	bore	A add to dim. M	B dia.	D rod exten.	E nose length	G flat	H flat	J rod thread x length	K nose thread	L port (NPSF)	M length	N		Q pilot	R Hex Flats.	X pilot dia. -.001 -.006
												for each stroke increment of:	add to M			
8-SH-	1/2	.19	.56	.75	.31	.12	.37	10-32 x .50	3/8-24	10-32 UNF	2.06	1/2"	.94	.04	.187	.375
7-SH-	3/4	.44	.81	.75	.44	.16	.62	1/4-28 x .50	1/2-20	1/8	2.25	1"	1.69	.07	.250	.500
6-SH-	1 1/16	.25	1.12	.75	.50	.25	.87	5/16-24 x .50	5/8-18	1/8	2.68	1"	1.56	.07	.375	.625
5-SH-	1 1/2	.19	1.55	1.25	.62	.25	.87	7/16-20 x 1.0	3/4-16	1/8	3.44	1"	1.69	.07	.437	.750

FABCO-AIR air cylinders

SHP-type single acting, non-rotating rod / pivot mount or double-end mount

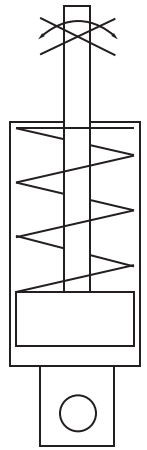

- Stainless steel rod, standard.
- Non-rotating hex rod-no special guides required.
- Requires air pressure only to extend rod.
- Stress relieved springs retract rod.
- Options: F, N, R, T and U.
- Versatile mounting, pivot, nose, double end.
- Available accessories: pivot bracket, foot mount, mounting nut and rod clevis, see pages 18 & 19.

For product configuration utility, 3D CAD viewer, and 3D CAD Model downloads, Visit www.fabco-air.com.

Media.....Compressed Air
 Pressure Range.....0-200 PSIG
 Temperature Range.....-40°F to 160°F Ambient*
 w/Fluoroelastomer.....-20°F to 400°F Ambient*
 Recommended maximum stroke......6"
 *additional heat may be generated by seal friction (high speed cycling).

model code.	piston area* - in ²		spring force pounds	
	volume - in ³ (per inch of stroke)	free	comp	
8	.20	1	2	
7	.44	1.5	5	
6	.89	4	8	
5	1.77	6	12	

*Area x PSIG = Approximate Force

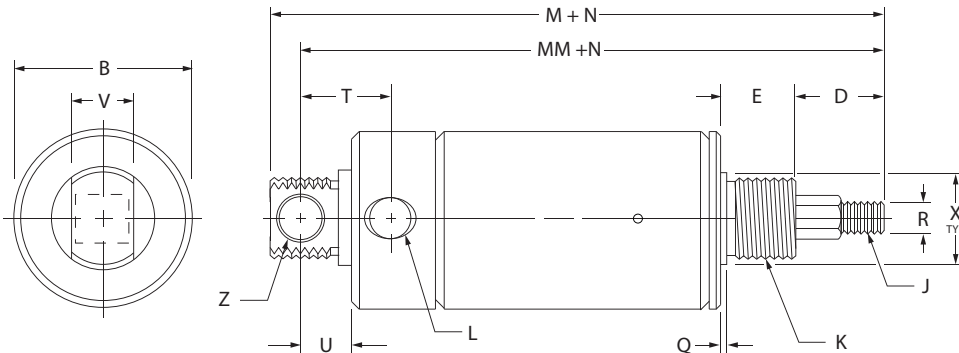

model & type (stroke)	bore	B dia.	D rod exten.	E nose length	J rod thread x length	K nose thread	L port (NPSF)	M length	MM length	N		Q pilot	R HEX FLATS	T	U	V	X pilot dia. -.001 -.006	Z Pivot Hole Dia.
										for each stroke increment of:	add to M							
8-SHP_-	1/2	.56	.75	.31	10-32 x .50	3/8-24	10-32 UNF	2.75	2.50	1/2"	.94	.04	.187	.42	.25	.31	.375 (.437)	.16
7-SHP_-	3/4	.81	.75	.44	1/4-28 x .50	1/2-20 (5/8-18)	1/8	3.31	3.02	1"	1.69	.07	.250	.66	.34	.38	.500 (.625)	.25
6-SHP_-	1 1/16	1.12	.75	.50	5/16-24 x .50	5/8-18	1/8	3.56	3.28	1"	1.56	.07	.375	.62	.34	.38	.625	.25
5-SHP_-	1 1/2	1.55	1.25	.62	7/16-20 x 1.0	3/4-16	1/8	4.50	4.13	1"	1.69	.07	.437	.81	.50	.62	.750	.38

FABCO-AIR air cylinders

SR-type single acting reverse / nose mount

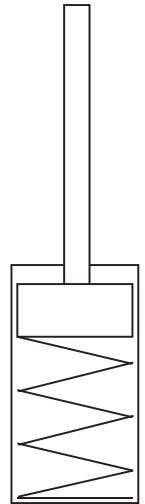

- Stainless steel rod, standard.
- Requires air pressure to retract rod.
- Stress relieved springs extend rod.
- Options: F, N, P and W.
- Wearstrip standard: 3 inches or more of stroke (optional, shorter strokes).
- Mounting nut included, except model 4 (order separately).
- Available accessories: foot mount and rod clevis, see pages 18 & 19.

For product configuration utility, 3D CAD viewer, and 3D CAD Model downloads, Visit www.fabco-air.com.

Media.....Compressed Air
 Pressure Range.....0-200 PSIG
 Temperature Range.....-40°F to 160°F Ambient*
 w/Fluoroelastomer.....-20°F to 400°F Ambient*
 Recommended maximum stroke......4"
 *additional heat may be generated by seal friction (high speed cycling).

model code.	piston area* - in ²		spring force pounds	
	volume - in ³ (per inch of stroke)		free	comp
8	.17		1	4
7	.39		1.5	7.5
6	.81		4	12
25	1.08		7	21
5	1.62		6	18
75	2.21		12	36
4	2.84		15	42

*Area x PSIG = Approximate Force

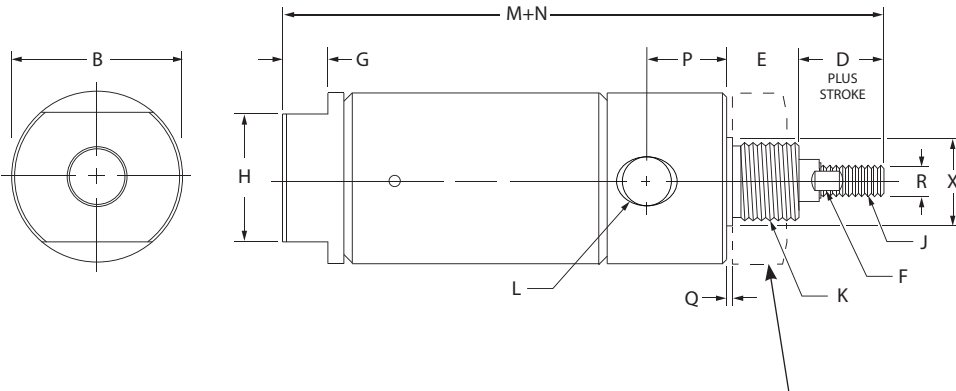

Mounting nut where applicable.
 For dimensions see page 19.

model & type (stroke)	bore	B dia.	D rod retracted	E nose length	F wrench flat	G flat	H flat	J rod thread x length	K nose thread	L port (NPSF)	M length (with rod extended)	N		P	Q pilot	R rod dia.	X pilot dia. -.001 -.006
												for each stroke increment of:	add to M				
8-SR_	1/2	.62	.50	.41	none	.12	.37	10-32 x .50	7/16-20	10-32 UNF	2.42	1/2"	1.44	.37	.04	.187	.437
7-SR_	3/4	.88	.50	.50	none	.16	.62	1/4-28 x .50	5/8-18	1/8	2.78	1"	2.69	.48	.07	.250	.625
6-SR_	1 1/16	1.12	.62	.50	.25	.25	.87	5/16-24 x .50	5/8-18	1/8	3.28	1"	2.56	.52	.07	.312	.625
25-SR_	1 1/4	1.31	1.00	.62	.38	.18	.87	7/16-20 x .75	3/4-16	1/8	4.25	1"	2.81	.63	.07	.437	.750
5-SR_	1 1/2	1.55	1.00	.62	.38	.25	.87	7/16-20 x .75	3/4-16	1/8	4.00	1"	2.69	.62	.07	.437	.750
75-SR_	1 3/4	1.81	1.19	.75	.44	.25	1.25	1/2-20 x .88	1-14	1/4	5.03	1"	3.00	.72	.09	.500	1.030
4-SR_	2	2.07	1.25	.81	.50	.31	1.25	1/2-20 x .88	1 1/4-12	1/4	5.11	1"	3.00	.69	.12	.625	1.375

FABCO-AIR air cylinders

SRP-type single acting reverse / pivot mount or double end mount

- Stainless steel rod, standard.
- Requires air pressure to retract rod.
- Stress relieved springs extend rod.
- Options: F, N, P and W.
- Wearstrip standard: 3 inches or more of stroke (optional, shorter strokes).
- Options: F, N, P, R, T, W and U.
- Versatile mounting, pivot, nose, double-end.
- Available accessories: pivot bracket, foot mount, mounting nut and rod clevis, see pages 18 & 19.

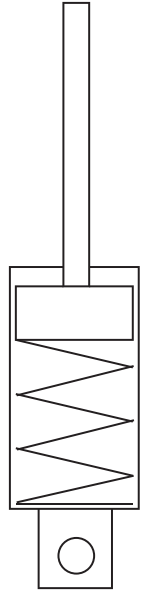

For product configuration utility, 3D CAD viewer, and 3D CAD Model downloads, Visit www.fabco-air.com.

Media.....Compressed Air
 Pressure Range.....0-200 PSIG
 Temperature Range.....-40°F to 160°F Ambient*
 w/Fluoroelastomer.....-20°F to 400°F Ambient*
 Recommended maximum stroke.....4"
 *additional heat may be generated by seal friction (high speed cycling).

model code.	piston area* - in ²		spring force pounds	
	volume - in ³ (per inch of stroke)		free	comp
8	.17		1	4
7	.39		1.5	7.5
6	.81		4	12
25	1.08		7	21
5	1.62		6	18
75	2.21		12	36
4	2.84		15	42

*Area x PSIG = Approximate Force

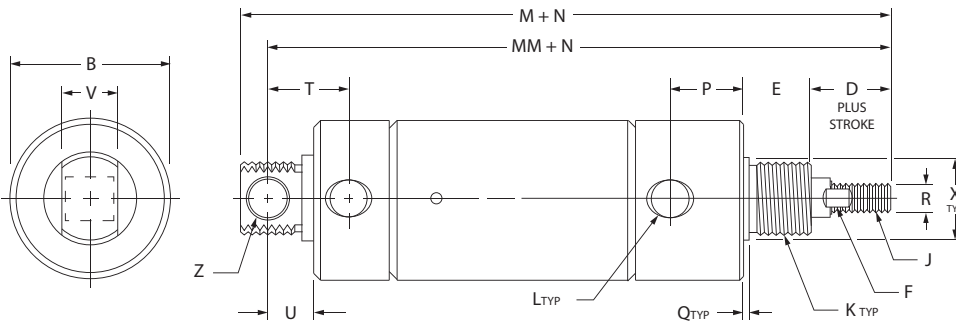

model & type (stroke)	bore	B dia.	D rod exten.	E nose length	F wrench flat	J rod thread x length	K nose thread	L port (NPSF)	M length (w/rod ext.)	MM length (w/rod ext.)	N		P	Q pilot	R rod dia.	T	U	V	X Pil. Dia. -.001 -.005	Z Pivot Hole Dia.
											for each stroke increment of:	add to M								
8-SRP_	1/2	.62	.50	.41	none	10-32 x .50	7/16-20	10-32 UNF	3.12	2.88	1/2"	1.44	.37	.04	.187	.42	.25	.31	.437	.16
7-SRP_	3/4	.88	.50	.50	none	1/4-28 x .50	5/8-18	1/8	3.84	3.55	1"	2.69	.48	.07	.250	.66	.34	.38	.625	.25
6-SRP_	1 1/16	1.12	.62	.50	.25	5/16-24 x .50	5/8-18	1/8	4.15	3.87	1"	2.56	.52	.07	.312	.62	.34	.38	.625	.25
25-SRP_	1 1/4	1.31	1.00	.62	.38	7/16-20 x .75	3/4-16	1/8	5.33	4.97	1"	2.81	.63	.07	.437	.91	.41	.50	.750	.25
5-SRP_	1 1/2	1.55	1.00	.62	.38	7/16-20 x .75	3/4-16	1/8	5.06	4.69	1"	2.69	.62	.07	.437	.81	.50	.62	.750	.38
75-SRP_	1 3/4	1.81	1.19	.75	.44	1/2-20 x .88	1-14	1/4	6.59	6.09	1"	3.00	.72	.09	.500	.98	.50	.62	1.030	.38
4-SRP_	2	2.07	1.25	.81	.50	1/2-20 x .88	1 1/4-12	1/4	6.48	6.05	1"	3.00	.69	.12	.625	1.0	.57	.75	1.375	.38

FABCO-AIR air cylinders

BFS-type

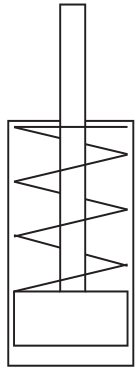

- Versatile mounting... through-head, front mount using pilot.
- Stainless steel rod, standard.
- Wearstrip standard 3" inches or more of stroke (optional on shorter strokes. N/A on model 8).
- BFS Options: F and N.
- Available accessories: rod clevis, see pages 18 & 19.

For product configuration utility, 3D CAD viewer, and 3D CAD Model downloads, Visit www.fabco-air.com.

Media.....Compressed Air
 Pressure Range.....0-200 PSIG
 Temperature Range.....-40°F to 160°F Ambient*
 w/Fluoroelastomer.....-20°F to 400°F Ambient*
 Recommended maximum stroke.....6"
 *additional heat may be generated by seal friction (high speed cycling).

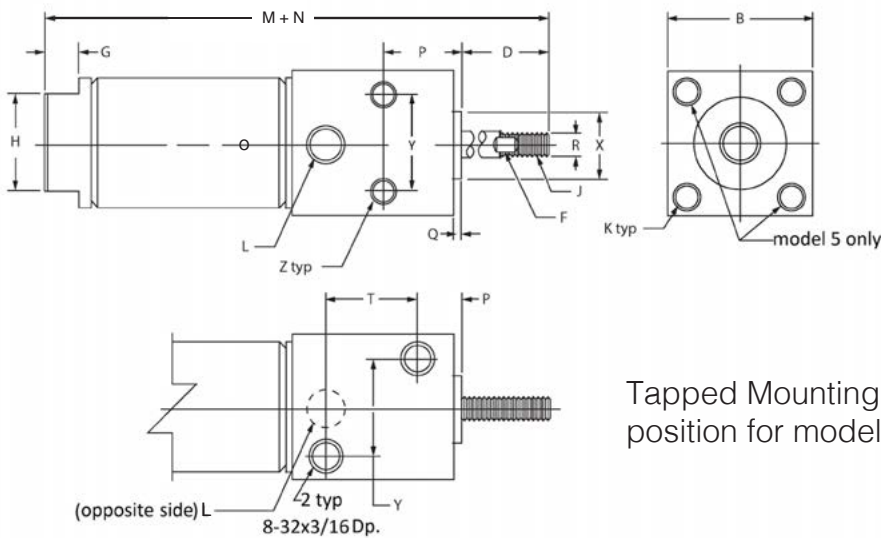

Tapped Mounting hole (Z) position for model 8-BFS only

model code	piston area* - in ² volume - in ³ (per inch of stroke)	spring force pounds	
		free	comp
8-BFS	.20	1	2
7-BFS	.44	1.5	5
6-BFS	.89	4	8
5-BFS	1.77	6	12

*Area x PSIG = Approximate Force

model & type (stroke)	bore	B square	D rod exten.	F Wrench flat	G flat	H flat	J rod thread x length	K mounting holes	L port (NPSF)	M length	N		P	Q pilot	R rod dia.	T	X pilot dia. -.001 -.006	Y	Z mounting holes
											for each stroke increment of:	add to M							
8-BFS_	1/2	.75	.50	none	.12	.37	10-32 x .50	Two #8-32 holes on .75 dia bolt circle	10-32 UNF	2.42	1/2"	.94	.31	.06	.187	.44	.437	.44	Two #8-32 holes
7-BFS_	3/4	1.00	1.06	.22	.16	.62	1/4-28 x .75	Two #10-32 holes on 1.0 dia bolt circle	1/8	3.34	1"	1.69	.47	.09	.250	.51	.625	.62	Two holes drill and c' bored for 10-32 cap screw tap 1/4-20
6-BFS_	1 1/16	1.25	1.12	.25	.25	.87	5/16-24 x .75	Two #10-32 holes on 1.25 dia bolt circle	1/8	4.28	1"	1.56	.72	.09	.312	.54	.750	.81	Two holes drill and c' bored for 10-32 cap screw tap 1/4-20
5-BFS_	1 1/2	1.75	1.50	.38	.25	.87	7/16-20 x 1.25	Two #1/4-20 holes on 1.75 dia bolt circle	1/4	5.00	1"	1.69	1.00	.12	.437	.66	1.000	1.12	Two holes drill and c' bored for 1/4-20 cap screw tap 5/16-18

FABCO-AIR air cylinders

BFSR-type

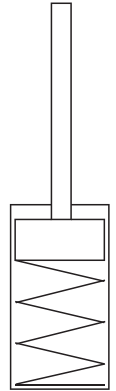

- Versatile mounting...
through-head, front mount using pilot.
- Stainless steel rod, standard.
- Wearstrip standard 3" inches or more of stroke (optional on shorter strokes. N/A on model 8).
- BFSR Options: F, N and P.
- Available accessories: rod clevis, see pages 18 & 19.

For product configuration utility, 3D CAD viewer, and 3D CAD Model downloads, Visit www.fabco-air.com.

Media.....Compressed Air
 Pressure Range.....0-200 PSIG
 Temperature Range.....-40°F to 160°F Ambient*
 w/Fluoroelastomer.....-20°F to 400°F Ambient*
 Recommended maximum stroke.....4"
 *additional heat may be generated by seal friction (high speed cycling).

model code	piston area* - in ²		spring force pounds	
	volume - in ³ (per inch of stroke)	free	comp	
8-BRSR	.17	1	4	
7-BFSR	.39	1.5	7.5	
6-BFSR	.81	4	12	
5-BFSR	1.62	8	18	

*Area x PSIG = Approximate Force

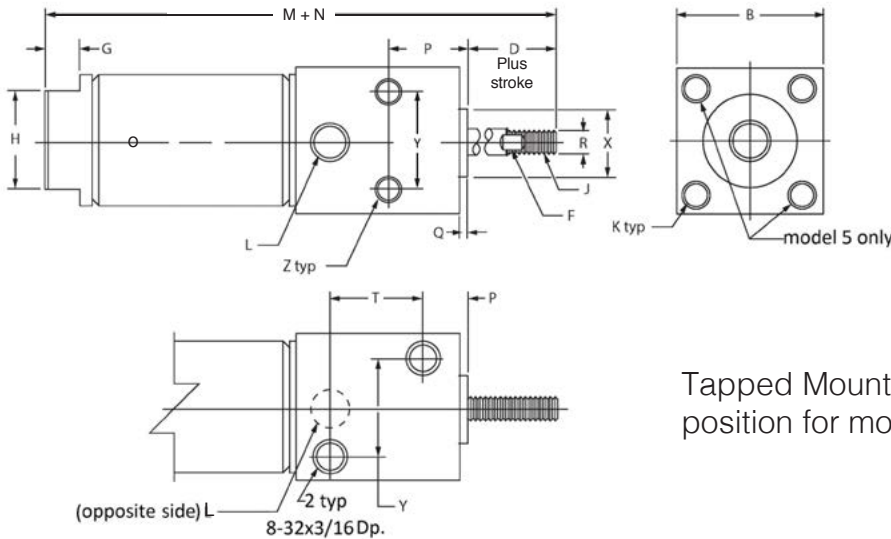

Tapped Mounting hole (Z)
position for model 8-BFSR only

model & type (stroke)	bore	B square	D rod exten.	F Wrench flat	G flat	H flat	J rod thread x length	K mounting holes	L port (NPSF)	M length	N		P	Q pilot	R rod dia.	T	X pilot dia. -.001 -.006	Y	Z mounting holes
											for each stroke increment of:	add to M							
8-BFSR_	1/2	.75	.50	none	.12	.37	10-32 x .50	Two #8-32 holes on .75 dia bolt circle	10-32 UNF	2.42	1/2"	1.44	.31	.06	.187	.44	.437	.44	Two #8-32 holes
7-BFSR_	3/4	1.00	1.06	.22	.16	.62	1/4-28 x .75	Two #10-32 holes on 1.0 dia bolt circle	1/8	3.34	1"	2.69	.47	.09	.250	.51	.625	.62	Two holes drill and c'bored for 10-32 cap screw tap 1/4-20
6-BFSR_	1 1/16	1.25	1.12	.25	.25	.87	5/16-24 x .75	Two #10-32 holes on 1.25 dia bolt circle	1/8	4.28	1"	2.56	.72	.09	.312	.54	.750	.81	Two holes drill and c'bored for 10-32 cap screw tap 1/4-20
5-BFSR_	1 1/2	1.75	1.50	.38	.25	.87	7/16-20 x 1.25	Two #1/4-20 holes on 1.75 dia bolt circle	1/4	5.18	1"	2.69	1.00	.12	.437	.66	1.000	1.12	Two holes drill and c'bored for 1/4-20 cap screw tap 5/16-18

• air cylinder accessories are made of carbon steel • burnished for surface smoothness • bright zinc plated for corrosion resistance

accessories

pivot bracket

- for use with pivot cylinders
- cylinders can pivot through 120°
- one-piece construction for strength and ease of cylinder installation/removal
- pivot pin and cotter pin supplied.

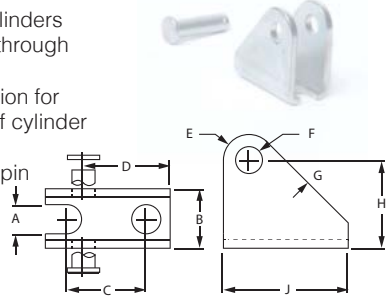

Model Number	Cylinder Bore Sizes (model code)	A	B	C	D	E	F	G	H	J
BP-8-C	1/2 (8)	.20	.52	.43	.54	.22	.16	50°	.64	.75
BP-11-C	3/4 (7) & 1 1/16 (6)	.26	.65	.75	.87	.31	.26	53°	.87	1.19
BP-25-C	1 1/4 (25)	.32	.77	.75	.94	.31	.26	53°	1.06	1.25
BP-15-C	1 1/2 (5) & 1 3/4 (75)	.39	.96	1.00	1.25	.38	.38	52°	1.37	1.63
BP-19-C	2 (4) & 2 1/2 (3)	.45	1.20	1.00	1.43	.38	.38	48°	1.68	1.81

rod clevis

- for use on all cylinders
- smooth beveled ends
- locknut, clevis pin and cotter pin supplied.

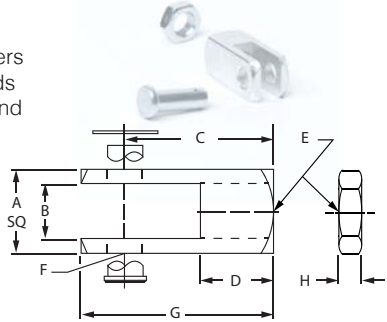

Model Number	Cylinder Bore Sizes (model code)	A	B	C	D	E	F	G	H
CT-8	1/2 (8)	.38	.19	.75	.38	10-32	.19	.94	.12
CT-7	3/4 (7)	.50	.25	.94	.50	1/4-28	.26	1.20	.16
CT-11	1 1/16 (6)	.50	.26	.94	.50	5/16-24	.26	1.20	.19
CT-15	1 1/4 (25) & 1 1/2 (5)	.75	.38	1.30	.75	7/16-20	.38	1.70	.25
CT-19	1 3/4(75), 2(4), 2 1/2(3)	.75	.38	1.30	.75	1/2-20	.38	1.70	.31

foot mount

- for nose mounting and double - end mounting
- gusseted for added strength

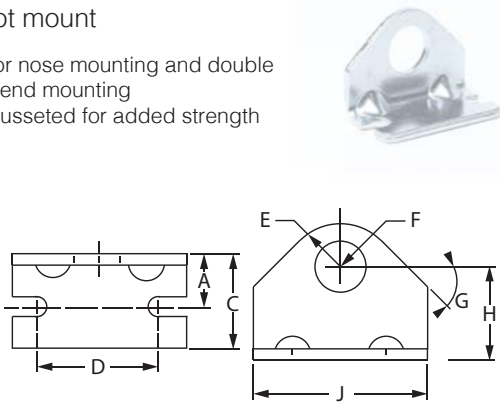

Model Number	Cylinder Bore Sizes (model code)	A	B	C	D	E	F	G	H	J
F-8-S	1/2(8) single acting types	.31	.19	.62	1.00	.37	.38	56°	.57	1.38
F-8	1/2(8) double acting types	.31	.19	.62	1.00	.37	.44	56°	.57	1.38
F-7	3/4(7) single acting types	.44	.19	.75	1.25	.40	.50	45°	.69	1.63
F-11	3/4(7) double acting 1 1/16(6) single & double acting types	.56	.27	1.00	1.50	.56	.63	45°	.81	1.88
F-15	1 1/4(25) & 1 1/2(5) All Types	.77	.27	1.50	1.89	.76	.76	49°	1.00	2.50
F-75	1 3/4(75) All Types	.94	.34	1.50	2.25	.88	1.04	52°	1.25	3.00
F-19	2(4) All Types	1.00	.34	1.62	2.25	1.00	1.38	60°	1.50	3.12
F-21	2 1/2 (3) All Types	1.00	.34	1.62	2.88	1.25	1.50	63°	1.75	3.75

*Model 8-SP requires one each JN-8-S and JN-8 for double end mount.

**Models 7-SP and 7-SHP require one each JN-7 and JN-11 for double end mount.

mounting nut / jam nut

- mounting nut for nose or pivot tang threads
- jam nut for locking rod clevis

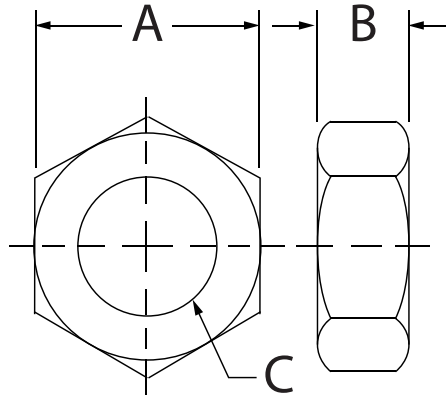

mounting nut #	where to use cylinder bore & type	A	B	C
JN-8-S	1/2(8) single acting	.56	.22	3/8-24
JN-8	1/2(8) double acting	.68	.25	7/16-20
JN-7	3/4(7) single acting	.75	.31	1/2-20
JN-11	3/4(7) double acting 1 1/16(6) all types	.93	.37	5/8-18
JN-15	1 1/4(25) all types 1 1/2(5) all types	1.12	.42	3/4-16
JN-75	1 3/4(75) all types	1.50	.56	1-14
JN-19	2(4) all types	1.88	.50	1 1/4-12
JN-21	2 1/2(3) All Types	2.06	.50	1 3/8-12

jam nut #	where to use cylinder bore size	A	B	C
C110-9	1/2(8)	.370	.12	10-32
C110-762	3/4(7)	.43	.16	1/4-28
C110-763	1 1/16(6)	.50	.19	5/16-24
JN-8	1 1/4(25) & 1 1/2(5)	.68	.25	7/16-20
JN-7	1 3/4(75) & 2(4) & 2 1/2(3)	.75	.31	1/2-20

FABCO-AIR volume chambers

C, CP, CPP types standard / end mount / double end mount

- C type: standard inline mount
- CP type: end mount
- CPP type: double end mount

- For vacuum or air
- Ideal for time delay circuits
- Stainless steel barrel
- Aluminum end caps
- Options: A and AA side porting.
- See page 18 and 19 for foot mount and mounting nuts. (CP, CPP models)



bore code	bore dia. in.	volume in ³	
		basic volume*	add per 1.0 inch length
8	1/2	.11	.20
7	3/4	.40	.44
6	1 1/16	.88	.89
25	1 1/4	1.44	1.23
5	1 1/2	1.68	1.77
75	1 3/4	3.29	2.41
4	2	4.04	3.14
3	2 1/2	6.38	4.91

*add this volume to sum of the per inch volume.
This basic volume exists before any 1-inch increments are added.

how to order

bore code — model — length — option

7 — C — 6 — A

see left — C — specify in inches — A

left — CP — AA

left — CPP — AA

example:

7-C-6A

5-CP-4

8-CPP-2-1/2



C Standard



C with side port option A

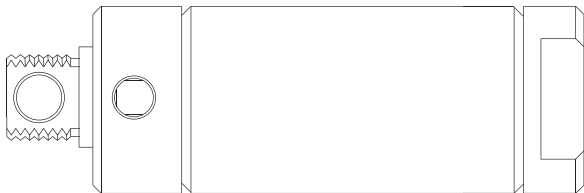

Model CP

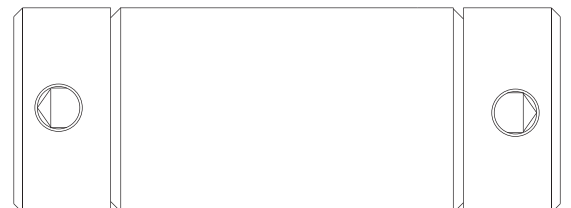

C with side port option AA



Model CPP

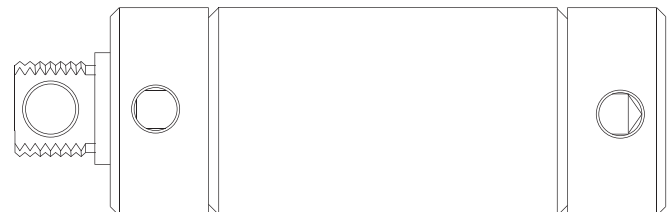

CP with side port option A

FABCO-AIR volume chambers dimensions



bore code	dimensions						
	A	B	C	D	E (NPSF)	F	G
8	1.35	.11	.37	.56	10-32 UNF	.96	.19
7	1.91	.16	.62	.81	1/8	1.35	.44
6	2.18	.25	.88	1.11	1/8	.88	.25
25	2.67	.18	.87	1.30	1/8	1.08	.31
5	2.26	.25	.88	1.55	1/8	1.06	.19
75	2.57	.25	1.24	1.80	1/4	1.56	.56
4	2.81	.32	1.25	2.07	1/4	1.37	.37
3	2.81	.31	2.07	2.61	1/4	1.37	.37

- For side porting, (option A) add dimension A & G to desired length. (double the G dimension for option AA, side porting both ends.)
- For end mount add dimension A & F to desired length. (Double the F dimensions for end mount both ends.)

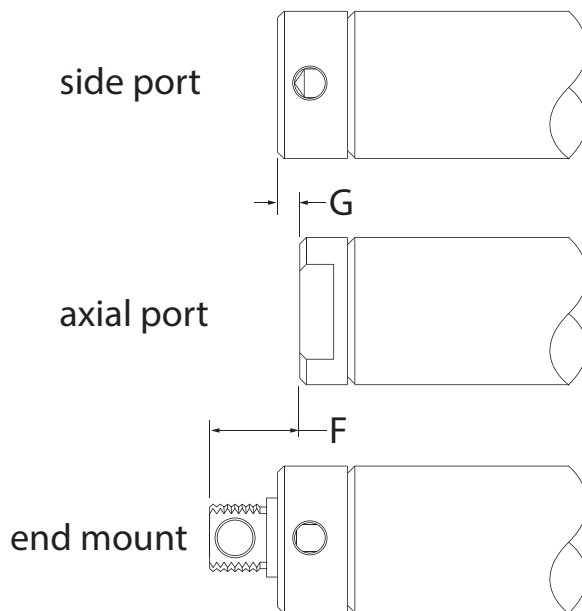
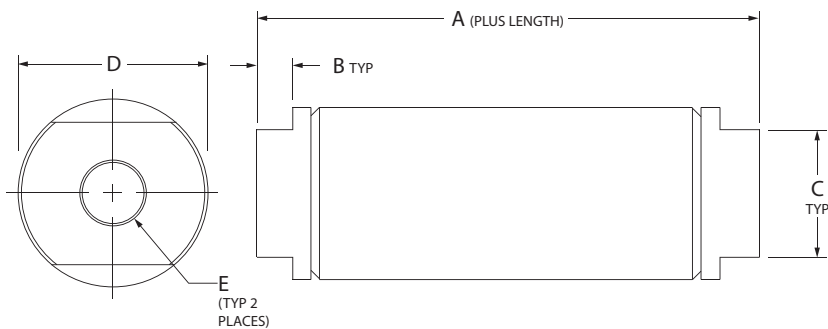

FABCO-AIR air cylinders

with position sensing

Fabco double acting air cylinders, type D, DP, and BFD may be ordered with Option M, an internal magnet factory installed on the reversible piston, permitting use with position sensing switches. Cylinder models with Option M are interchangeable in length with other Fabco air cylinders, facilitating conversions of existing applications.



sensor switches

lead length : 24 inches standard
lead length : 144 inches = Option L

basic on/off reed switch

RS2 / RS2-L

on/off reed switch w/LED

RS4 / RS4-L

Contacts: SPST Form A (normally open)
Contact Rating: 50W Max.
Voltage Rating: 200 VDC Max.
141 VAC Max.

Switching current: 1A Max.
Initial Contact Resistance: 1 Ohm Max.
Minimum Breakdown Voltage: 225 VDC
275 VAC
Temperature Range: -40°F to 200°F
(-40°C to 93°C)

CONTACT RATING

POWER CURVE

Curve Equation
50W >= Voltage x current

non-contact solid state switch

GMR1 / GMR1-L (NPN)

SENSOR	OPEN	CLOSED
LED	OFF	ON

GMR1 / GMR1-L (PNP)

SENSOR	OPEN	CLOSED
LED	OFF	ON

R = V/I Ohms (> 5 Watts)
V = Switch Voltage (Volts)
I = Switch Current Consumption
x60% safety factor (amps)

POWER CURVE

Curve Equation
300mW <= Voltage x current

Giant MagnetoResistance (GMR) Effect
Input Voltage : 5 to 30 VDC
Input Current : 25 mA Max.
Output Voltage Drop : .4V Max.
Output Current : 330 mA Max.
Reverse Input Voltage Protection
Power Dissipation : 300 mW Max.
Temperature Range : -20°F to 185°F
(-29°C to 85°C)

PSMK Mounting Kit: Mounts sensor to Fabco Cylinder.
Assembly instructions are included with shipment.

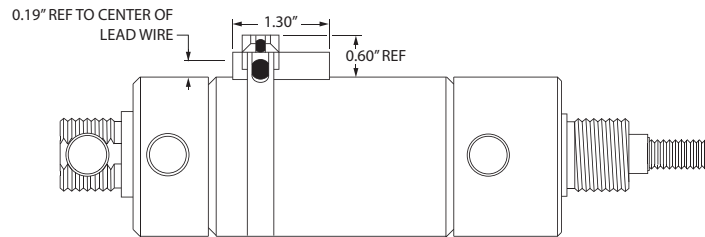

Prices effective Jan 2, 2017

Switches		Price
RS-2	Reed	\$23.63
RS-2L	Reed w/144" Lead	\$32.53
RS-2-PSMK	Reed w/Mounting	\$29.76
RS-2L-PSMK	Reed w/144" leads & Mtg	\$38.65
RS-4	Reed - LED	\$33.36
RS-4L	Reed - LED w/144" Leads	\$43.68
RS-4-PSMK	Reed - LED w/Mtg	\$39.49
RS-4L-PSMK	Reed - LED w/144" Leads & Mtg	\$49.81
GMR-1	Solid State	\$37.70
GMR-1L	Solid State w/144" Leads	\$48.14
GMR-1-PSMK	Solid State w/Mounting	\$43.83
GMR-1L-PSMK	Solid State w/144" leads &Mtg	\$54.27
PSMK	Sensor Switch Mounting Kit	\$5.75

how to order

RS4	L	PSMK
Model	Lead Length	Mount
RS2	24 in: -	w/o Mt: -
RS4	144 in: L	w/Mt: PSМК
GMR1		

Cylinder Accessories

Magnetic Position Sensors

FABCO-AIR
Prices effective Jan 2, 2017

Temperature range: -4° to +176°F (-20° to +80C)

Magnetically operated reed switches and electronic sensors can be mounted anywhere along the length and circumference of the cylinder. A magnetic piston is required.

Dovetail Style Sensors		Prewired 9 ft. Leadwire		Quick Disconnect*	
Sensor Type	Electrical Characteristics	Part No.	Price	Part No.	Price
Reed (No LED)	0-120 VDC/VAC, 0.5 Amp Max current, 5 Watt Max, 0 Voltage Drop	949-000-001	\$18.95	949-000-301	\$26.95
Reed (LED)	5-120 VDC/VAC, 0.03 Amp Max current, 4 Watt Max, 2.0 Voltage Drop	949-000-002	19.80	949-000-302	27.60
Electronic (LED)	Sourcing PNP 5-28 VDC, 0.20 Amp Max current, 1.0 Voltage Drop	949-000-031	25.00	949-000-331	32.85
Electronic (LED)	Sinking NPN 5-28 VDC, 0.20 Amp Max current, 1.0 Voltage Drop	949-000-032	25.00	949-000-332	32.85

*Note: Quick disconnect styles are supplied with 6 inch pigtail with male connector. Order female cordsets separately from chart below.

- Encased in a plastic housing, dovetail style sensors are corrosion resistant. 60° wire outlet allows close mounting.
- Two methods of mounting are available: one is fastened to the cylinder barrel with a **band clamp** (not included with sensor – must be ordered separately); the second is an adhesive-backed **mounting rail** with twin dovetail slots.

Sensor slides into extruded aluminum rail and is locked in place with a screw.

H-Series cylinder with rail mounted dovetail sensors shown on one of Fabco-Air's linear slide products.

Mounting Options

Band Clamp Adapter for Dovetail Sensors
(Must be ordered separately)
Part No. 900-300-000
Price: \$8.55

Dovetail Rail as shown above (must be ordered separately). Order by **Part No. "ER – length"** where the length is known, or by "ER – cylinder model no." Example: "ER-6-DP-4M" Model no. of cylinder allows factory to determine the length needed. (Estimated length for pricing purposes is "stroke + 1")
Price: \$3.10 + \$1.10 per inch length
Supplied with double sided tape affixed.
Application recommendations:
a) Clean cylinder body O.D. with acetone. Remove all oil from surface.

- Do not apply the rail over the crimped body edge.
 - Double check positioning of the rail.
 - High performance double sided tape offers convenient "peel and stick" but is very aggressive, giving you only one chance. Be careful !
 - Remove protective film from tape and place rail in desired position.
 - Firmly press the rail to cylinder body.
- Alternatively, the extruded aluminum rail can be fastened using Loctite® U-05FL urethane adhesive or similar. Follow product manufacturer's recommendations for application.

Clamp on Style Sensors		Prewired 9 ft. Leadwire		Quick Disconnect*	
Sensor Type	Electrical Characteristics	Part No.	Price	Part No.	Price
Reed (LED)	5-120 VAC/VDC, 0.5 AMP Max, 10 Watt Max, SPST N.O. 3.5 voltage drop	9-2A197-1003	\$31.40	9-2A197-1303	\$40.45
Electronic (LED)	Sourcing, PNP, 6-24 VDC, 0.5 Amp Max, 1.0 voltage drop	9-2A197-1031	33.65	9-2A197-1331	43.15
Electronic (LED)	Sinking, NPN, 6-24 VDC, 0.5 Amp Max, 1.0 voltage drop	9-2A197-1032	33.65	9-2A197-1332	43.15

Band Clamp for Clamp On Sensors
(must be ordered separately)
Part No. 800-A00-000 **Price: \$8.10**



Prewired style sensors are supplied with a 9 foot leadwire.

*Quick disconnect style sensors are supplied with male connector as shown in this photo. Order female cordsets separately from the chart below.

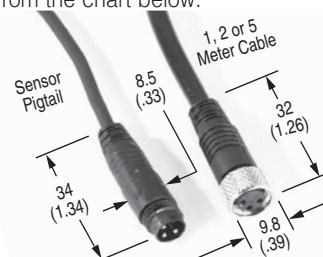

Female Cordsets for Quick Disconnect Sensors		
Cordset Length	Part No.	Price
1 Meter	CFC-1M	\$15.05
2 Meters	CFC-2M	16.85
5 Meters	CFC-5M	21.30

FABCO-AIR deluxe rod ends

Exclusive with Fabco Air Cylinders (except SH, SHP, and D2EY models), you may choose from 15 unique, custom rod-end design selections, and have Fabco tailor it to your exact requirements.

End Workbook. Expect normal lead times and no minimum order quantities. A unique model number is assigned at the initial build cycle. That part number is permanently available for future orders of the same make.

The 15 themes are shown below, and address customizable features such as rod extension length, wrench flat position, male or female rod thread and rod thread length, plain rod end, rounded rod end, ring grooves, rod diameter reductions, and (cotter) pin holes.

Examples of part numbers utilizing codes below are: 7-S-2 DX01-00039 and 5-S-1N DX12-00015.

Each of the 15 different rod end selections includes a specific set of user definable dimensions selected from the Deluxe Rod

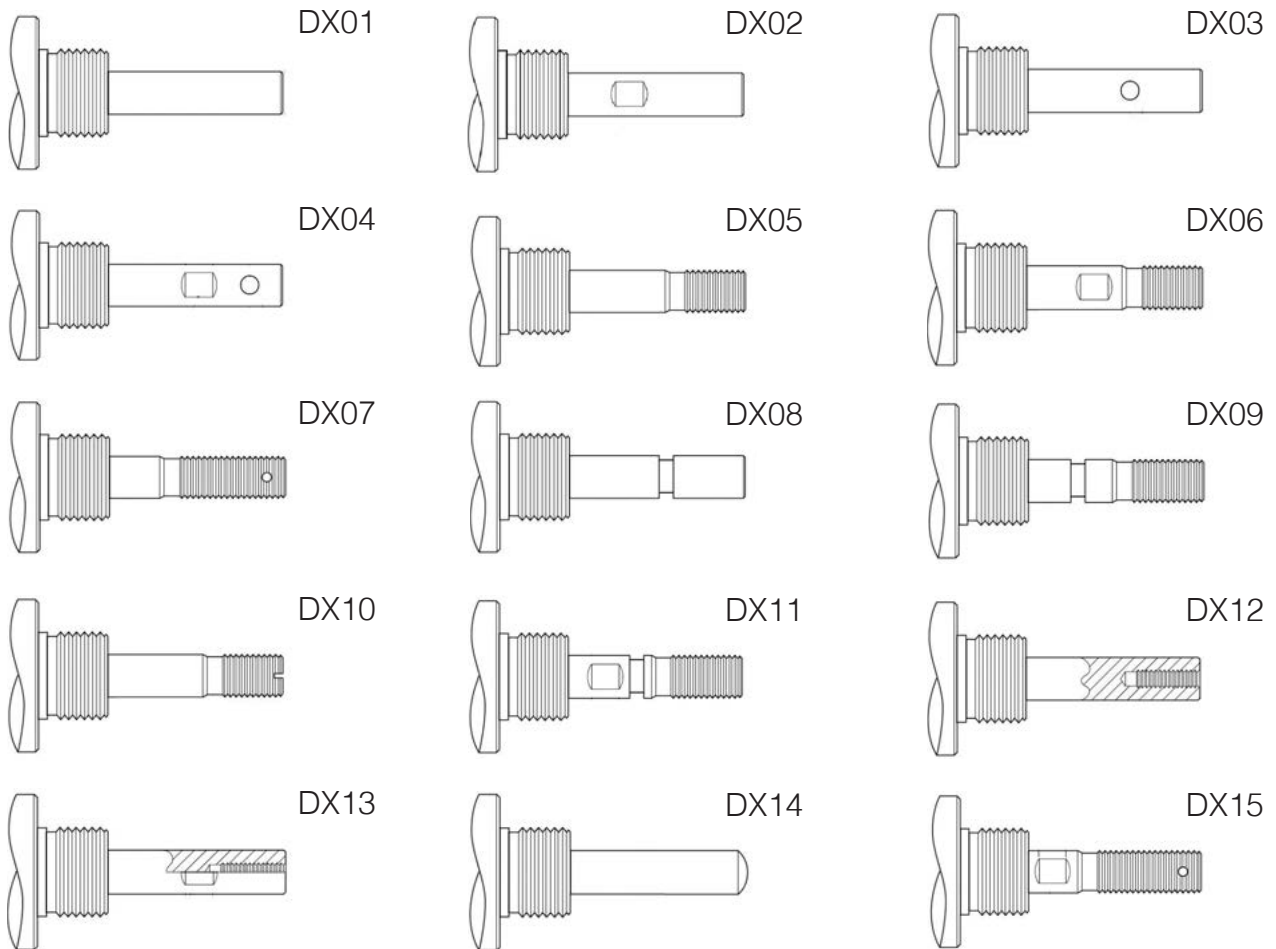

example:

6-DP-1 DX05-00145

DX05-00145 specs:
 D=1.5"
 J=10-32 UNF
 JL=0.25"

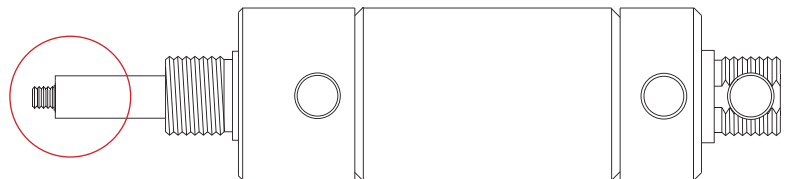

Model	Base	Stroke per 1/2"	Bumper B	Magnet M	FKM (Viton) F	Wearstrip N	Rod Wiper W	Side Port A	Rotate 90 J	Rotate 180 K	Rotate 270 L	PolyPk P	Rotate tang R	Pivot Pin T	Pivot Bush U
D	\$18.06	\$0.94	\$4.14	\$5.40	\$9.78	x	x	\$3.50	x	x	x	\$7.53	x	x	x
DP	\$22.27	\$0.94	\$4.14	\$5.40	\$9.78	x	x	x	\$1.35	\$1.35	\$1.35	\$7.53	\$4.07	\$2.10	x
D2EY	\$29.60	\$1.19	STD	x	\$12.54	x	x	x	\$1.35	\$1.35	\$1.35	\$15.05	x	x	x
S	\$17.45	\$1.70	x	x	\$5.30	x	x	\$3.50	x	x	x	x	x	x	x
SP	\$23.05	\$1.70	x	x	\$5.30	x	x	x	x	x	x	x	\$5.45	\$2.10	x
SH	\$22.05	\$1.70	x	x	\$5.30	x	x	\$3.50	x	x	x	x	x	x	x
SHP	\$27.85	\$1.70	x	x	\$5.30	x	x	x	x	x	x	x	\$5.45	\$2.10	x
SR	\$26.95	\$1.70	x	x	\$9.20	x	x	\$3.50	x	x	x	\$7.53	x	x	x
SRP	\$33.50	\$1.70	x	x	\$9.20	x	x	x	x	x	x	\$7.53	\$5.45	\$2.10	x
BFD	\$28.48	\$0.94	\$4.14	\$5.40	\$9.78	x	x	x	x	x	x	\$7.53	x	x	x
BFS	\$31.85	\$1.70	x	x	\$5.30	x	x	\$3.50	x	x	x	x	x	x	x
BRSR	\$41.65	\$1.70	x	x	\$9.20	x	x	\$3.50	x	x	x	x	x	x	x
C	\$10.67	\$0.72	x	x	x	x	x	\$2.54	x	x	x	x	x	x	x
CP	\$14.78	\$0.72	x	x	x	x	x	\$2.54	x	x	x	x	x	x	x
CPP	\$19.24	\$0.72	x	x	x	x	x	x	x	x	x	x	x	x	x

Accessories		Price
CT-8	Rod Clevis	\$3.17
F-8-S	Foot Mount	\$1.97
F-8	Foot Mount	\$1.97
JN-8-S	Jam Nut	\$0.65
JN-8	Jam Nut	\$0.55
BP-8-C	Pivot Bracket	\$3.30

Model 7 (3/4 Bore)

Model	Base	Stroke per 1"	Bumper B	Magnet M	FKM (Viton) F	Wearstrip N	Rod Wiper W	Side Port A	Rotate 90 J	Rotate 180 K	Rotate 270 L	PolyPk P	Rotate tang R	Pivot Pin T	Pivot Bush U
D	\$18.30	\$1.76	\$4.14	\$5.71	\$9.78	\$2.90	\$6.61	\$3.50	x	x	x	\$7.63	x	x	x
DP	\$22.63	\$1.76	\$4.14	\$5.71	\$9.78	\$2.90	\$6.61	x	\$1.35	\$1.35	\$1.35	x	x	\$2.00	x
D2EY	\$32.74	\$2.33	STD	x	\$12.54	\$2.90	x	x	\$1.35	\$1.35	\$1.35	x	x	x	x
S	\$19.45	\$3.25	x	x	\$5.30	\$2.90	x	\$3.50	x	x	x	x	x	x	x
SP	\$24.25	\$3.25	x	x	\$5.30	\$2.90	x	x	x	x	x	x	x	\$2.00	x
SH	\$23.65	\$3.25	x	x	\$5.30	\$2.90	x	\$3.50	x	x	x	x	x	x	x
SHP	\$29.50	\$3.25	x	x	\$5.30	\$2.90	x	x	x	x	x	x	x	\$2.00	x
SR	\$28.40	\$3.25	x	x	\$9.20	\$2.90	x	\$3.50	x	x	x	x	x	x	x
SRP	\$34.80	\$3.25	x	x	\$9.20	\$2.90	x	x	x	x	x	x	x	\$2.00	x
BFD	\$28.48	\$1.76	\$4.14	\$5.71	\$9.78	\$2.90	x	x	x	x	x	x	x	x	x
BFS	\$34.35	\$3.25	x	x	\$5.30	\$2.90	x	\$3.50	x	x	x	x	x	x	x
BRSR	\$43.30	\$3.25	x	x	\$9.20	\$2.90	x	\$3.50	x	x	x	x	x	x	x
C	\$11.15	\$0.90	x	x	x	x	x	\$2.53	x	x	x	x	x	x	x
CP	\$16.11	\$0.90	x	x	x	x	x	\$2.53	x	x	x	x	x	x	x
CPP	\$20.74	\$0.90	x	x	x	x	x	\$2.53	x	x	x	x	x	x	x

Accessories		Price
CT-7	Rod Clevis	\$3.30
F-7	Foot Mount	\$1.97
F-11	Foot Mount	\$2.25
JN-7	Jam Nut	\$0.72
JN-11	Jam Nut	\$0.72
BP-11-C	Pivot Bracket	\$3.23

Model 6 (1-1/16 Bore)

x = NOT APPLICABLE

Model	Base	Stroke per 1"	Bumper B	Magnet M	FKM (Viton) F	Wear strip N	Rod Wiper W	Side Port A	Rotate 90 J	Rotate 180 K	Rotate 270 L	PolyPk P	Rotate tang R	Pivot Pin T	Pivot Bush U
D	\$21.82	\$1.76	\$4.14	\$6.07	\$11.86	\$3.20	\$8.22	\$3.50	x	x	x	\$7.53	x	x	x
DP	\$26.09	\$1.76	\$4.14	\$6.07	\$11.86	\$3.20	\$8.22	x	\$1.35	\$1.35	\$1.35	\$7.53	\$4.07	\$2.00	\$10.86
D2EY	\$38.78	\$2.44	STD	x	\$14.94	\$3.20	x	x	\$1.35	\$1.35	\$1.35	\$15.05	x	x	x
S	\$21.65	\$4.10	x	x	\$6.35	\$3.20	x	\$3.50	x	x	x	x	x	x	x
SP	\$26.90	\$4.10	x	x	\$6.35	\$3.20	x	x	x	x	x	x	\$4.07	\$2.00	\$10.86
SH	\$25.90	\$4.10	x	x	\$6.35	\$3.20	x	\$3.50	x	x	x	x	x	x	x
SHP	\$37.10	\$4.10	x	x	\$6.35	\$3.20	x	x	x	x	x	x	\$4.07	\$2.00	\$10.86
SR	\$31.35	\$4.10	x	x	\$10.80	\$3.20	\$9.60	\$3.50	x	x	x	\$10.05	x	x	x
SRP	\$37.10	\$4.10	x	x	\$10.80	\$3.20	\$9.60	x	x	x	x	\$10.05	\$4.07	\$2.00	\$10.86
BFD	\$34.43	\$1.76	\$4.14	\$6.07	\$11.86	\$3.20	x	x	x	x	x	\$7.53	x	x	x
BFS	\$42.05	\$4.10	x	x	\$6.35	\$3.20	x	\$3.50	x	x	x	x	x	x	x
BRSR	\$50.90	\$4.10	x	x	\$10.80	\$3.20	\$9.60	\$3.50	x	x	x	\$10.05	x	x	x
C	\$11.81	\$1.21	x	x	x	x	x	\$2.53	x	x	x	x	x	x	x
CP	\$16.04	\$1.21	x	x	x	x	x	\$2.53	x	x	x	x	x	x	x
CPP	\$20.62	\$1.21	x	x	x	x	x	\$2.53	x	x	x	x	x	x	x

Accessories		Price
CT-11	Rod Clevis	\$3.29
F-11	Foot Mount	\$2.25
JN-11	Jam Nut	\$0.72
BP-11-C	Pivot Bracket	\$3.23

Model 25 (1-1/4 Bore)

Model	Base	Stroke per 1"	Bumper B	Magnet M	FKM (Viton) F	Wearstrip N	Rod Wiper W	Side Port A	Rotate 90 J	Rotate 180 K	Rotate 270 L	PolyPk P	Rotate tang R	Pivot Pin T	Pivot Bush U
D	\$31.92	\$2.25	\$4.14	\$6.07	\$11.86	\$3.20	\$9.21	\$3.50	x	x	x	\$7.53	x	x	x
DP	\$38.20	\$2.25	\$4.14	\$6.07	\$11.86	\$3.20	\$9.21	x	\$1.35	\$1.35	\$1.35	\$7.53	\$5.40	\$4.56	\$6.68
D2EY	\$53.11	\$3.45	STD	x	\$14.94	\$3.20	x	x	\$1.35	\$1.35	\$1.35	x	x	x	x
S	\$33.95	\$5.10	x	x	\$6.35	\$3.20	x	\$3.50	x	x	x	x	x	x	x
SP	\$41.80	\$5.10	x	x	\$6.35	\$3.20	x	x	x	x	x	x	\$5.40	\$4.56	\$6.68
SR	\$44.30	\$5.10	x	x	\$10.80	\$3.20	\$9.21	\$3.50	x	x	x	\$7.53	x	x	x
SRP	\$48.65	\$5.10	x	x	\$10.80	\$3.20	\$9.21	x	x	x	x	\$7.53	\$5.40	\$4.56	\$6.68
C	\$13.33	\$1.43	x	x	x	x	x	\$2.53	x	x	x	x	x	x	x
CP	\$19.42	\$1.43	x	x	x	x	x	\$2.53	x	x	x	x	x	x	x
CPP	\$25.52	\$1.43	x	x	x	x	x	\$2.53	x	x	x	x	x	x	x

Accessories		Price
CT-15	Rod Clevis	\$5.47
F-15	Foot Mount	\$3.30
JN-15	Jam Nut	\$1.00
BP-25-C	Pivot Bracket	\$4.87

Model 5 (1-1/2 Bore)

x = NOT APPLICABLE

Model	Base	Stroke per 1"	Bumper B	Magnet M	FKM (Viton) F	Wear strip N	Rod Wiper W	Side Port A	Rotate 90 J	Rotate 180 K	Rotate 270 L	PolyPk P	Rotate tang R	Pivot Pin T	Pivot Bush U
D	\$37.07	\$2.63	\$4.52	\$6.77	\$13.05	\$3.56	\$9.21	\$3.50	x	x	x	\$7.52	x	x	x
DP	\$42.34	\$2.63	\$4.52	\$6.77	\$13.05	\$3.56	\$9.21	x	\$1.35	\$1.35	\$1.35	\$7.52	\$5.45	\$2.77	\$8.80
D2EY	\$58.64	\$4.27	STD	x	\$16.50	\$3.56	x	x	\$1.35	\$1.35	\$1.35	x	x	x	x
S	\$40.60	\$5.85	x	x	\$7.45	\$3.56	x	\$3.50	x	x	x	x	x	x	x
SP	\$47.05	\$5.85	x	x	\$7.45	\$3.56	x	x	x	x	x	x	\$5.45	\$2.77	\$8.80
SH	\$45.15	\$5.85	x	x	\$7.45	\$3.56	x	\$3.50	x	x	x	x	x	x	x
SHP	\$52.15	\$5.85	x	x	\$7.45	\$3.56	x	x	x	x	x	x	\$5.45	\$2.77	\$8.80
SR	\$50.40	\$5.85	x	x	\$11.75	\$3.56	\$9.21	\$3.50	x	x	x	\$7.52	x	x	x
SRP	\$57.40	\$5.85	x	x	\$11.75	\$3.56	\$9.21	x	x	x	x	\$7.52	\$5.45	\$2.77	\$8.80
BFD	\$54.19	\$2.63	\$4.52	\$6.77	\$13.05	\$3.56	x	\$3.50	x	x	x	\$7.52	x	x	x
BFS	\$64.60	\$5.85	x	x	\$7.45	\$3.56	x	\$3.50	x	x	x	x	x	x	x
BRSR	\$72.20	\$5.85	x	x	\$11.75	\$3.56	\$9.21	\$3.50	x	x	x	\$7.52	x	x	x
C	\$15.98	\$1.75	x	x	x	x	x	\$2.53	x	x	x	x	x	x	x
CP	\$21.06	\$1.75	x	x	x	x	x	\$2.53	x	x	x	x	x	x	x
CPP	\$26.12	\$1.75	x	x	x	x	x	\$2.53	x	x	x	x	x	x	x

Accessories		Price
CT-15	Rod Clevis	\$5.47
F-15	Foot Mount	\$3.30
JN-15	Jam Nut	\$1.00
BP-15-C	Pivot Bracket	\$5.12

Model 75 (1-3/4 Bore)

Model	Base	Stroke per 1"	Bumper B	Magnet M	FKM (Viton) F	Wear strip N	Rod Wiper W	Side Port A	Rotate 90 J	Rotate 180 K	Rotate 270 L	PolyPk P	Rotate tang R	Pivot Pin T	Pivot Bush U
D	\$54.19	\$2.94	\$4.52	\$6.77	\$13.05	\$3.56	\$10.54	\$3.50	x	x	x	\$7.53	x	x	x
DP	\$61.02	\$2.94	\$4.52	\$6.77	\$13.05	\$3.56	\$10.54	x	\$1.35	\$1.35	\$1.35	\$7.53	\$4.08	\$2.77	\$8.80
D2EY	\$78.15	\$5.56	STD	x	\$16.50	\$3.56	x	x	\$1.35	\$1.35	\$1.35	x	x	x	x
S	\$59.35	\$7.95	x	x	\$7.45	\$3.56	x	\$3.50	x	x	x	x	x	x	x
SP	\$68.70	\$7.95	x	x	\$7.45	\$3.56	x	x	x	x	x	x	\$4.08	\$2.77	\$8.80
SR	\$71.95	\$7.95	x	x	\$11.75	\$3.56	\$10.54	\$3.50	x	x	x	\$7.53	x	x	x
SRP	\$73.55	\$7.95	x	x	\$11.75	\$3.56	\$10.54	x	x	x	x	\$7.53	\$4.08	\$2.77	\$8.80
C	\$18.63	\$2.05	x	x	x	x	x	\$2.53	x	x	x	x	x	x	x
CP	\$25.52	\$2.05	x	x	x	x	x	\$2.53	x	x	x	x	x	x	x
CPP	\$32.32	\$2.05	x	x	x	x	x	\$2.53	x	x	x	x	x	x	x

Accessories		Price
CT-19	Rod Clevis	\$5.46
F-75	Foot Mount	\$5.12
JN-75	Jam Nut	\$2.30
BP-15-C	Pivot Bracket	\$5.12

Model 4 (2" Bore)

x = NOT APPLICABLE

Model	Base	Stroke per 1"	Bumper B	Magnet M	FKM (Viton) F	Wearstrip N	Rod Wiper W	Side Port A	Rotate 90 J	Rotate 180 K	Rotate 270 L	PolyPk P	Rotate tang R	Pivot Pin T	Pivot Bush U
D	\$55.31	\$2.94	\$5.97	\$7.89	\$16.50	\$3.86	\$10.53	\$3.95	x	x	x	\$7.53	x	x	x
DP	\$67.85	\$2.94	\$5.97	\$7.89	\$16.50	\$3.86	\$10.53	x	\$1.35	\$1.35	\$1.35	\$7.53	\$4.08	x	x
D2EY	\$82.97	\$5.60	STD	x	\$22.13	\$3.86	x	x	\$1.35	\$1.35	\$1.35	x	x	x	x
S	\$76.55	\$8.45	x	x	\$9.53	\$3.86	x	\$3.95	x	x	x	x	x	x	x
SP	\$94.60	\$8.45	x	x	\$9.53	\$3.86	x	x	x	x	x	x	\$4.08	x	x
SR	\$89.80	\$8.45	x	x	\$16.55	\$3.86	\$10.53	\$3.95	x	x	x	\$7.53	x	x	x
SRP	\$98.30	\$8.45	x	x	\$16.55	\$3.86	\$10.53	x	x	x	x	\$7.53	\$4.08	x	x
C	\$24.06	\$2.16	x	x	x	x	x	\$3.80	x	x	x	x	x	x	x
CP	\$36.13	\$2.16	x	x	x	x	x	\$3.80	x	x	x	x	x	x	x
CPP	\$48.13	\$2.16	x	x	x	x	x	\$3.80	x	x	x	x	x	x	x

Accessories		Price
CT-19	Rod Clevis	\$5.46
F-19	Foot Mount	\$7.63
JN-19	Jam Nut	\$3.95
BP-19-C	Pivot Bracket	\$10.19

Model 3 (2-1/2" Bore)

Model	Base	Stroke per 1"	Bumper B	Magnet M	FKM (Viton) F	Wear strip N	Rod Wiper W	Side Port A	Rotate 90 J	Rotate 180 K	Rotate 270 L	PolyPk P	Rotate tang R	Pivot Pin T	Pivot Bush U
D	\$80.08	\$3.20	\$5.97	\$9.54	\$16.50	\$3.86	\$3.86	\$3.95	x	x	x	\$7.53	x	x	x
DP	\$93.70	\$3.20	\$5.97	\$9.54	\$16.50	\$3.86	\$3.86	x	\$1.35	\$1.35	\$1.35	\$7.53	\$4.08	x	x
D2EY	\$110.96	\$6.21	STD	x	\$22.13	\$3.86	\$3.86	x	\$1.35	\$1.35	\$1.35	x	x	x	x
C	\$38.78	\$2.96	x	x	x	x	x	\$3.80	x	x	x	x	x	x	x
CP	\$51.81	\$2.96	x	x	x	x	x	\$3.80	x	x	x	x	x	x	x
CPP	\$64.89	\$2.96	x	x	x	x	x	\$3.80	x	x	x	x	x	x	x

Accessories		Price
CT-19	Rod Clevis	\$5.46
F-21	Foot Mount	\$7.63
JN-21	Jam Nut	\$3.95
BP-19-C	Pivot Bracket	\$10.19

Notes

Notes

Notes

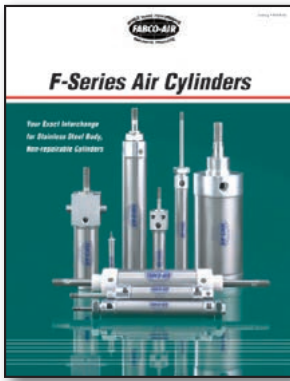

F-Series Air Cylinders
 Your Exact Interchange for Stainless Steel Body, Non-repairable Cylinders
 Stainless Steel Body
 Air Cylinders
 Catalog #SSB-03

For more options see our F-Series Catalog or visit the configure page at FABCO-AIR.COM



Fabco-Air.com



Price & Delivery



Downloadable CAD

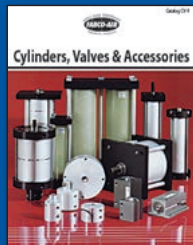

Cylinders, Valves and Accessories
 Catalog #CV9

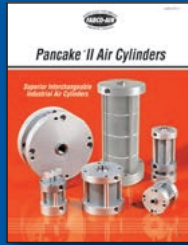

Pancake® II Air Cylinders
 Catalog #Pan2-2

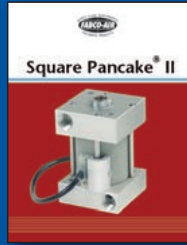

Square Pancake® II Air Cylinders
 Catalog #SqPan2

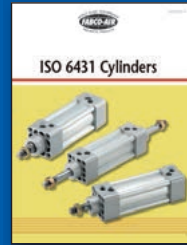

ISO 6431 Cylinders
 Catalog #FAQ2R-14

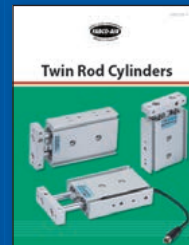

Twin Rod, Non-Rotating Air Cylinders - Catalogs #FDF-09 & #FDXS-09

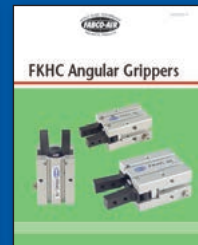

High Closing Force Angular Grippers
 Catalog #FKHC-10



Multi-Power® Air Presses
 Catalog #FP16

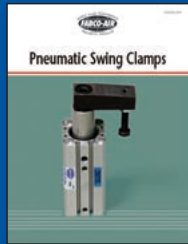

Swing Clamps
 Catalog #SC-DB04

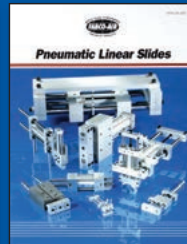

Linear Slides - 6 Families
 Catalog #LS-03



Compact Finger Slides
 Catalog #FDH-10



ISO 6432 Cylinders
 Catalog #FAE-09

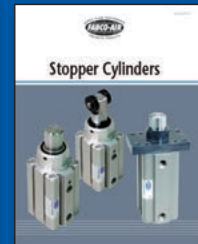

Stopper Cylinders
 Catalog #ST-SC

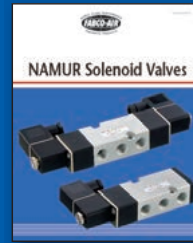

NAMUR Solenoid Valves
 Catalog #FVEN-10

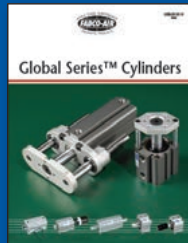

Global Series™ Metric Air Cylinders
 Catalog #GC-15

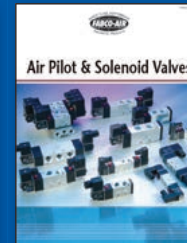

Air Pilot and Solenoid Valves
 Catalog #FVA.E-09



Air Table Slides
 Catalog #FGXS-10



Wide & Narrow Parallel Grippers - Catalogs #FKHZ-10 & #FKHQ-10



Toggle Type Angular Grippers
 Catalog #FKHT-10

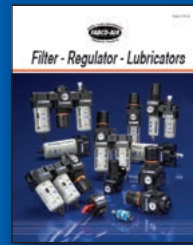

Modular Air Preparation System - FRLs
 Catalog #FRL-06

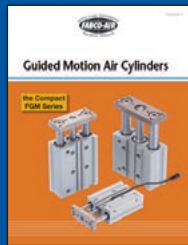

Guided Motion Air Cylinders
 Catalog #FGM-10

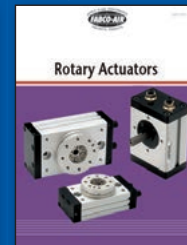

Pneumatic Rotary Actuators
 Catalog #FRA.C-09



3 Series of Angular & Parallel Motion Grippers
 Catalog #GR8



Pneumatic & Hydraulic Swing Clamps
 Catalog #FML.H

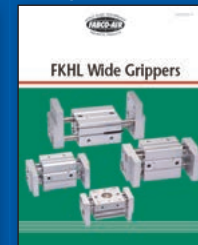

Wide Opening Parallel Grippers
 Catalog #FKHL-10